

Dell™ PowerVault™ 725N Systems Service Manual

[System Overview](#)
[Indicators, Messages, and Codes](#)
[Basic Troubleshooting](#)
[Removing and Replacing Parts](#)
[Jumpers and Connectors](#)
[Using the System Setup Utility](#)



NOTE: A NOTE indicates important information that helps you make better use of your computer.



NOTICE: A NOTICE indicates either potential damage to hardware or loss of data and tells you how to avoid the problem.



CAUTION: A CAUTION indicates a potential for property damage, personal injury, or death.

Information in this document is subject to change without notice.
© 2003 Dell Inc. All rights reserved.

Reproduction in any manner whatsoever without the written permission of Dell Inc. is strictly forbidden.

Trademarks used in this text: *Dell*, the *DELL* logo, *PowerVault*, *Dell ActiveArchive*, and *Dell OpenManage* are trademarks of Dell Inc.; *Intel*, *Pentium*, and *Celeron* are registered trademarks of Intel Corporation; *Novell* and *NetWare* are registered trademarks of Novell, Inc.; *Microsoft*, *Windows*, *Windows NT* and *MS-DOS* are registered trademarks of Microsoft Corporation; *UNIX* is a registered trademark of The Open Group in the United States and other countries; *VESA* is a registered trademark of Video Electronics Standards Association.

Other trademarks and trade names may be used in this document to refer to either the entities claiming the marks and names or their products. Dell Inc. disclaims any proprietary interest in trademarks and trade names other than its own.

Initial Release: 15 Nov 2002
Last revised: 25 Aug 2003

[Back to Contents Page](#)

Basic Troubleshooting

Dell™ PowerVault™ 725N Systems Service Manual

- [Initial User Contact](#)
- [External Visual Inspection](#)
- [Determining if a NAS System Uses Software RAID or Hardware RAID](#)
- [Observing the Boot Routine](#)
- [Internal Visual Inspection](#)
- [Running the System Diagnostics](#)
- [Running the System Diagnostics Program](#)
- [Running the Dell OpenManage Hard-Drive Diagnostics Program](#)
- [Running the NIC Diagnostics Program](#)

Performing basic troubleshooting procedures can often reveal the source of a system problem or indicate a starting point for servicing the system.

 **NOTE:** While it is recommended that you use a keyboard, mouse, and monitor to observe boot activity and system messages, you can also use console redirection from a client system connected by serial cable to the NAS system. For more information about using console redirection, see "Using Console Redirection" in the *Installation and Troubleshooting Guide*.

Perform the following procedures in the order presented.

Initial User Contact

Ask the user to describe the problem and the conditions under which it occurs. Next, perform the following steps:

1. Have the user back up the data on the hard drive, if possible.

Refer the user to the documentation provided with the operating system or application software for information about backing up data.

2. Have the user duplicate the problem.

If the user cannot duplicate the problem, proceed to "[External Visual Inspection](#)."

3. Observe the user's actions for errors such as typing an incorrect key combination or entering a command incorrectly.

If the problem is a result of user error, instruct the user in the proper procedure. If it is not, proceed to "[External Visual Inspection](#)."

4. View and capture the Event Log for error messages.
-

External Visual Inspection

1. Inspect the status indicators for indications of component malfunction.
2. Turn off the system and all attached peripherals.
3. Verify that all power cables are properly connected to the system, peripherals, and their power sources.
4. Ensure that cables are properly connected to devices.
5. If a monitor is used, inspect the monitor controls for obvious damage or improper settings.

For proper settings of the monitor controls, see the monitor documentation.

6. If a keyboard is used, inspect the keyboard to ensure that keys are not sticking.

If keys are sticking, replace the keyboard.

7. Inspect the system and peripherals for signs of physical damage.

If a peripheral is damaged, see the peripheral documentation. If the system is damaged, see "[Internal Visual Inspection](#)."

Determining if a NAS System Uses Software RAID or Hardware RAID

The NAS system is available from Dell in either a software-RAID or a hardware-RAID hard-drive configuration. In a software-RAID hard-drive configuration NAS system, the RAID functionality is configured by the Microsoft® Windows® Powered operating system. The hard drives in a hardware-RAID hard-drive configuration NAS system are controlled by a RAID controller card installed in a PCI expansion slot inside the NAS system.

 **NOTICE:** The software RAID and hardware RAID hard-drive carriers operate differently and are not interchangeable between the two types of NAS systems. The hardware RAID hard-drive carriers have a "HW-RAID" identification label on them and the software RAID hard-drive carriers have a "SW-RAID" identification label.

The RAID hard-drive configuration of the NAS system affects some of the NAS Manager configuration procedures. Therefore, determine the RAID configuration of your NAS system before continuing with other procedures.

Use one of the following methods to determine the RAID configuration:

1. Check the RAID hard drive configuration on the NAS system **System Version** screen.
 - a. Log in to the NAS Manager.
 - b. Click **Status**.
 - c. Click **System Version**.

The **System Version** screen appears and the **Disk Configuration** row lists the system as either **Hardware RAID** or **Software RAID**.

1. Check if the system has a RAID controller card installed in a PCI expansion slot. "See [Replacing the RAID Controller](#)." If so, the NAS system is hardware RAID. (A software-RAID NAS system does not have a RAID controller card installed in a PCI expansion slot.)
-

Observing the Boot Routine

 **NOTE:** Most steps in this procedure require observation of system functions and indications, some of which can occur simultaneously. You may need to reboot the system several times to complete all of these steps.

1. If the system is off, turn on all peripherals and the system. If the system is on, reboot the system.
2. During the boot routine, observe the system for any of the following indications:
 1. Beep codes indicate an error condition. See "[System Beep Codes](#)."
 1. System error messages indicate problems or provide status information. See "[System Messages](#)."
 1. Drive indicators light when data is transferred to or from the drives. If a drive indicator fails to light during the boot routine, troubleshoot the appropriate drive subsystem.
 1. Three indicators on the upper-right corner of the keyboard should flash momentarily.

If the indicators flashed, proceed to the next step.

If the indicators did not flash, replace the keyboard with a keyboard that you know works. If the problem persists, troubleshoot the system power supply. If the troubleshooting procedure indicates that the system power supply is working, troubleshoot the memory. See the *Installation and Troubleshooting Guide*.

3. Observe the power-supply indicators.

If the fault indicator(s) is lit, troubleshoot the system power supply. See the *Installation and Troubleshooting Guide*.

Internal Visual Inspection

 **NOTICE:** Before proceeding with the internal visual inspection, save all open files and exit all open applications, if possible.

Visual inspection of a system's interior can often locate the source of a problem, such as a loose expansion card or cable connector. See "[Jumpers and Connectors](#)" to locate components referenced in the inspection procedure.

 **CAUTION:** See your *System Information Guide* for complete information about safety precautions, working inside the computer, and protecting against electrostatic discharge.

 **NOTICE:** When you turn off the system, press the power button for less than 2 seconds. If you press the power button for longer than 3 seconds, the system will automatically rebuild the RAID arrays the next time the system is turned on. This could impact system performance for several hours.

1. Turn off the system, including attached peripherals, and disconnect the system from the electrical outlets.

 **CAUTION:** The microprocessor and heat-sink assembly can get extremely hot during system operations. Ensure that both components have had sufficient time to cool before touching them.

 **CAUTION:** When handling the processor and heat-sink assembly, avoid sharp edges on the heat sink.

2. Remove the system cover. See "[Removing the System Cover](#)."
3. Ensure that all components (memory modules, expansion cards, and processors) are properly and securely installed.
4. Verify that all jumpers are set correctly. See "[Jumpers and Connectors](#)."
5. Ensure that all cables inside the system are firmly attached to their appropriate connectors.
6. Replace the system cover. See "[Replacing the System Cover](#)."
7. Reconnect the system to the electrical outlet and turn on the system, including attached peripherals.

If the problem is resolved, no further steps are necessary. If the problem is not resolved, go to "[Observing the Boot Routine](#)."

Running the System Diagnostics

Several tools are available to help diagnose problems when your NAS system or one of its components is not operating properly. The system diagnostics program allows you to run tests on the entire system or on specific system components such as memory, hard drives, video, and USB. Additionally, separate programs are available to help you diagnose problems with hard drives and NICs. [Table 2-1](#) describes diagnostics programs available for your NAS system and its components.

Table 2-1. NAS System Diagnostics Programs

Component	Diagnostics Program
System	System diagnostics program. See " Running the System Diagnostics Program ."
Memory	System diagnostics program. See " Running the System Diagnostics Program ."
Hard drives	Dell OpenManage™ Hard-Drive Diagnostics program. See " Running the Dell OpenManage Hard-Drive Diagnostics Program ."
	System diagnostics program. See " Running the System Diagnostics Program ."
Video	System diagnostics program. See " Running the System Diagnostics Program ."
USB	System diagnostics program. See " Running the System Diagnostics Program ."
NIC	NIC diagnostics program. See " Running the NIC Diagnostics Program ."

Running the System Diagnostics Program

The system's BIOS ROM contains diagnostic software that can be launched during system boot that allows you to test hardware components to identify problems.

The following categories of tests are available from the diagnostics main menu:

- 1 System (see "[System Tests](#)")
- 1 Memory (see "[Memory Tests](#)")
- 1 Hard drives (see "[IDE Tests](#)")
- 1 Video (see "[Video Tests](#)")
- 1 USB (see "[USB Test](#)")

You can set test parameters and run tests on individual components by selecting the component from the main menu, or you can use the **Options** menu to run tests on multiple components. See "[Using the System Diagnostics Program Options Menu to Run Tests and Generate Test Reports.](#)"

Using the System Diagnostics Program

To enter the System Diagnostics program, perform the following steps.

-  **NOTE:** When you turn off the system, press the power button for less than 2 seconds. If you press the power button for longer than 3 seconds, the system will automatically rebuild the RAID arrays the next time the system is turned on. System performance could be impacted for several hours.

1. Turn off the NAS system.
2. Connect a keyboard, mouse and monitor to the NAS system.

-  **NOTE:** While it is recommended that you use a keyboard, mouse, and monitor to access system diagnostics, you can also use console redirection from a client system connected by serial cable to the NAS system. For more information, see "Using Console Redirection" in the *Installation and Troubleshooting Guide*.

3. Restart the NAS system.
4. Press <F2> immediately after you see the following message:

Press <F2> to Enter the Function Select Menu

If you wait too long and the operating system begins to boot, allow the system to complete the boot, and then shut down the system and try again.

5. When the **Function Select** menu appears, press <5> to run the system diagnostics program.
6. Press <y> to confirm that you want to run diagnostics.

-  **NOTE:** The system diagnostics program does not start until the power-on self test (POST) is complete.

Navigating the System Diagnostics Program

[Table 2-2](#) lists the basic keys used to view or change information in the system diagnostics program and to exit the program. [Table 2-3](#) lists the function keys that provide a short-cut to specific system diagnostics program functions.

Table 2-2. System Diagnostics Program Navigation Keys

Keys	Function
<Shift>, <Tab>, or down arrow	Moves to the next field.
Up arrow	Moves to the previous field.
Right arrow	Moves to the next menu.
Left arrow	Moves to the previous menu.
Space bar	Selects or deselects options on menus. Selected options are identified by a check mark.
<Enter>	Starts a test on an individual component or displays submenus.
<Esc>	Cancels the current operation or returns to the previous menu. On the main menu, <Esc> exits the system diagnostics program and reboots the system.

For most of the options, any changes you make are recorded but do not take effect until you reboot the system. For a few options (as noted in the help area at the bottom of the screen), the changes take effect immediately.

Table 2-3. System Diagnostics Program Function Keys

Key	Function
<F2>	Edit batch parameters.
<F3>	Load batch parameters.
<F4>	Save batch parameters.
<F5>	Select/deselect current test.
<F6>	Select/deselect All Tests in Menu.
<F7>	Select/deselect All Tests.
<F8>	Select/deselect All Quick Tests.
<F9>	List function keys.
<F10>	Run the selected test.

Types of System Diagnostics Program Tests

System Tests

System tests help identify problems with system-board components such as processors, controllers, buses, and so on.

Select **System** from the system diagnostics program main menu to access the following tests:

- 1 **Processor Tests** – Tests processor functionality. The system diagnostics program provides four processor tests:
 - o **Basic Functionality Test** – Verifies that the processor operates correctly and efficiently in all addressing modes. The test is performed in 16-bit real mode.
 - o **Processor Speed Test** – Determines and displays the processor clock speed. The screen displays the expected processor speed and the actual processor clock speed. processor speed is determined by measuring the number of processor clock cycles that occur in a known time period.
 - o **CPU Protected Mode Test** – Verifies the protected-mode instructions used by the operating system for switching to protected mode.
 - o **Coprocessor Test** – Checks the functionality of the math coprocessor. This test loads and stores the control and status word, checks data transfer between the processor and the math coprocessor, and tests exception checking while the data transfer is in progress.
- 1 **DMA Controller Test** – Performs a series of read and write tests on the memory address registers and page registers of the DMA controllers.
- 1 **Interrupt Controller Test** – Performs a series of read and write tests on interrupt mask registers and checks for stray interrupts after masking off all interrupts.
- 1 **Timer Test** – Checks the accuracy of the timer count by calibrating it against the periodic interrupt of the Real Time Clock (RTC).
- 1 **Real Time Clock Test** – Checks the regularity of the real time clock interrupt by calibrating it against the timer 0 interrupt.
- 1 **CMOS Validity Test** – Checks the validity of the data in CMOS RAM and makes sure that the CMOS RAM checksum is correct. This test also ensures that the battery is in good condition.
- 1 **Speaker Test** – Performs test on system speaker and allows you to adjust the volume.
- 1 **PCI System Test** – Scans the PCI bus for all PCI devices and checks their configurations.
- 1 **SMBus Test** – Checks that the System Management Bus (SMBus) works properly. This test consists of the SMBus general test and the SMB access test.
- 1 **Hardware Monitor Tests** – Reads the values for temperature, fan speed, and voltage to verify that they are within a specified range using the following tests:
 - o **Temperature and Fan Speed Test**
 - o **Voltage Test**

Memory Tests

Memory tests, which report the size of system memory, write to all areas of installed DDR system memory up to 3 GB. The system diagnostics program isolates faulty memory modules and displays a message that identifies the location of the faulty memory.

Select **Memory** from the system diagnostics program main menu to access the following tests:

- 1 **BIOS ROM Test** – Checks the data path of the BIOS ROM and makes sure the ROM is write-protected.
- 1 **Parity Test** – Finds parity errors in all system memory. This test is the best way to identify and report data corruption because of DRAM system memory hardware problems. This test diagnoses the parity error detection circuitry in DRAM.
- 1 **Pattern Test** – Includes test routines that write a series of test patterns to memory, then read the patterns back and compare the read results with the pattern that was written. The memory read and write instructions test all of DRAM.
- 1 **Extended Pattern Test** – Includes test routines that write data to memory, read the data back, and compare the data.
- 1 **Walking 1's Test** – Uses the Walking 1's Left Test and the Walking 1's Right Test routines to identify shorts on data lines and data bits that are hung at 1.
- 1 **Walking 0's Test** – Writes shifting patterns to memory to find memory errors. This test uses the Walking 0's Left Test and the Walking 0's Right Test to identify open data lines.
- 1 **Random Memory Test** – Writes a random bit pattern to a randomly selected DRAM system memory location and reads the same memory location, looking for the same bit pattern that was written.
- 1 **Address Test** – Checks for short and open circuits on address lines.
- 1 **Refresh Test** – Checks the DRAM system memory refresh interval rate and compares with the ISA standard.
- 1 **Data Bus Test** – Ensures that the data bus works properly by testing individual lines of the data bus.
- 1 **Cache Memory Test** – Identifies and tests the external cache memory, and then performs a random pattern test within the range of the cache memory size to detect cache memory problems.
- 1 **Quick Memory Test** – Quickly verifies that the entire installed memory can be accessed.

IDE Tests

When you are unable to access the operating system, the system diagnostics program's IDE tests can be used to perform read tests on the hard drives to determine if they are functioning properly.

 **NOTE:** If you are able to access your operating system, it is recommended that you use the Dell OpenManage Hard-Drive Diagnostics program to test your hard drives online. See "[Running the Dell OpenManage Hard-Drive Diagnostics Program](#)."

 **NOTE:** With the exception of the IDE HDD Quick Test, the following IDE tests can take up to a day to complete. It is recommended that you first run the quick test to see if the problem can be quickly identified before running more comprehensive tests.

Select **IDE** from the system diagnostics program main menu to access the following tests:

- 1 **IDE HDD Read Test** – Performs sequential and random read operations on the specified part of the IDE drive.
- 1 **IDE HDD Verify Test** – Performs sequential and random read and verify operations on the specified part of the IDE drive.
- 1 **IDE HDD Seek Test** – Determines the head movement ability of the hard drive over the specified cylinder and head range. It consists of a sequential seek test and random seek test.
- 1 **IDE HDD Quick Test** – Verifies that the software can fully access the selected IDE hard drive. The test reads small blocks of sectors at the beginning, middle, and end of the hard drive.

Video Tests

Video tests perform read, write, and compare tests on the video memory to determine if the video controller and the monitor are functioning properly.

Select **Video** from the diagnostics main menu to access the following tests:

- 1 **Video Controller Tests**
 - o **VGA Controller Test** – Tests the VGA controller.
 - o **Video Memory Test** – Performs read, write, compare tests on the video controller.
 - o **VESA Video Memory Test** – Checks the VESA® video memory.
- 1 **Video Monitor Tests**
 - o **Attribute Test** – Checks the attributes of the display adapter.
 - o **Page Selection Test** – Checks display pages.
 - o **Color Test** – Checks foreground, background, and border colors.
 - o **Text Mode Test** – Checks the text mode character sets of the display adapter.
 - o **Graphics Mode Test** – Checks the graphics mode of the display adapter.
 - o **VESA Video Modes Test** – Tests the supported VESA video modes.

USB Test

The USB test verifies functionality of the USB. Select **USB** from the system diagnostics program main menu to access the test.

Using the System Diagnostics Program Options Menu to Run Tests and Generate Test Reports

The system diagnostics program allows you to run tests on multiple components using the **Options** menu. The **Options** menu also allows you to set test parameters for batch tests, configure specific batch tests for user interaction, run quick tests and test reports. See "[Logging System Diagnostics Program Test Results](#)" for instructions about running reports. Select **Options** from the system diagnostics program main menu to perform the following tasks:

1. **Download Report** – Downloads a report to the console using XMODEM protocol.
1. **Edit Batch Parameters** – Edits parameters for batch tests.
1. **Load Batch Parameters** – Loads batch parameters from the console using XMODEM protocol.
1. **Save Batch Parameters** – Saves batch parameters.
1. **Generate Report** – Generates test reports.
1. **Clear Report** – Clears the test report log.
1. **Display Error Log File** – Allows you to view the test report log online.
1. **Toggle All Tests in Menu** – Selects or deselects all of the tests on a selected menu. For instance, you could toggle all the tests under the **Memory** menu.
1. **Toggle All Tests** – Selects or deselects all of the tests in the system diagnostics program.
1. **Toggle All Quick Tests** – Selects or deselects tests that are classified as Quick Tests.
1. **Run Selected Tests** – Runs all tests that have been selected on a particular menu. Selected tests have a check mark to the left of them.
1. **Toggle Hidden Test Display** – Displays or hides tests that are hidden by default, making them available for selection on the menu.

Logging System Diagnostics Program Test Results

Use the **Options** menu to select how you want to report system diagnostics program test results. You can log test results ranging from detailed (such as all test names, time started, time ended, and error) to basic results that show only the error.

The error log identifies errors by an error code. See the **errorcodes.txt** file on your *Resource* CD for information about the codes. You can generate a report and view it online, or download it to a client system using a HyperTerminal connection.

Generating a Report

1. Run the system diagnostics program tests.
2. Select the **Options** menu, select **Generate Report**, and press <Enter>.
3. Select **Continue** and press <Enter>.

Viewing a Report

To view the test report, select the **Options** menu, select **Display Error Log File**, and press <Enter>.

Downloading a Report

1. Setup a HyperTerminal connection between a client and the NAS system. See "Using Console Redirection" in the *Installation and Troubleshooting Guide*.
2. From a HyperTerminal session, run system diagnostics program tests. See "[Running the System Diagnostics Program](#)."
3. After running the diagnostics test, select **Options**, select **Download Reports**, and press <Enter>.
4. From the HyperTerminal window, select **Transfer**, and then select **Receive file**.

5. Enter the location where you want to save the report, select **XModem** as the protocol, and then click **Receive**.
6. Enter the filename of the report using the extension of your text editor (for example, test1.txt), and click **OK**.
7. Open the text file to view the report.

Clearing the Test Log

The system diagnostics program report includes information for the entire test log, which contains all tests that you have run. To clear the test log, select the **Options** menu, select **Clear Report**, and press <Enter>. The test log clears, and the next test report shows only results from tests run since you cleared the log.

Running the Dell OpenManage Hard-Drive Diagnostics Program

The Dell OpenManage Hard-Drive Diagnostics program enables you to test storage components online and verify if a hard drive is functional.

While it is possible to use the IDE test function of the system diagnostics program to diagnose your hard drives, if you are able to access your operating system, it is recommended that you use the Dell OpenManage Hard-Drive Diagnostics program instead. If you are unable to access your operating system, use the system diagnostics program to test hard drives. See "[Running the System Diagnostics Program](#)."

The Dell OpenManage Hard-Drive Diagnostics program allows you to test drives attached to your NAS system through either a Dell-qualified SCSI adapter or IDE adapter and determine the status of the attached disks.

The Dell OpenManage Hard-Drive Diagnostics program can be accessed from the desktop of the NAS system. For information about using the program, see the online help.

Running the NIC Diagnostics Program

 **NOTE:** Using Terminal Services to run the NIC diagnostics program may cause your Terminal Services session to disconnect. In the event you lose the connection, wait a few minutes and then log in again. The test results will be displayed after logging in. Also, you may perform the NIC diagnostics tests using a keyboard, monitor, and mouse attached directly to the NAS system.

To run the NIC diagnostics program:

1. Log into the NAS Manager.
2. Click **Maintenance**.
3. Click **Terminal Services**, and then log into the NAS system as an administrator.

 **NOTE:** The default administrator user name is `administrator` and the default password is `powervault`.

4. Click **Administrative Tools** on the **Advanced Administration** menu.
5. Click **Broadcom Network Teaming**.

The Broadcom Advanced Control Suite launches.

6. Click the **Diagnostics** tab.
7. In the left window, click the adapter (NIC) you want to test.
8. In the right window, select the tests you want to run OR click **Select All** to select all tests.
9. Click **Test** to run selected tests.

For more information, see the online help for your NIC.

[Back to Contents Page](#)

Indicators, Messages, and Codes

Dell™ PowerVault™ 725N Systems Service Manual

- [Front-Panel Indicators](#)
- [Back-Panel Indicators](#)
- [System Messages](#)
- [System Beep Codes](#)
- [System Board LED Codes](#)
- [NAS Manager Messages](#)

This section describes how the NAS system alerts you to system problems, and lists possible causes and actions you can take to resolve these problems.

The following are ways the NAS system can alert you to a problem or potential problem:

- 1 LED indicators for the system and the hard drives
- 1 System messages
- 1 System beep codes
- 1 System board LED codes
- 1 NAS Manager messages

The following sections provide more information about LED indicators, system messages and beep codes, and NAS Manager messages. For information on diagnostics messages, see "[Running the System Diagnostics](#)."

Front-Panel Indicators

Two types of LED indicators are available on the system's front panel. See [Figure 3-1](#). The indicators along the bottom of the front panel indicate hard-drive status, and the indicators near the power button indicate system status. [Table 3-1](#) details the conditions associated with each front-panel LED indicator code.

Figure 3-1. Front-Panel Indicators

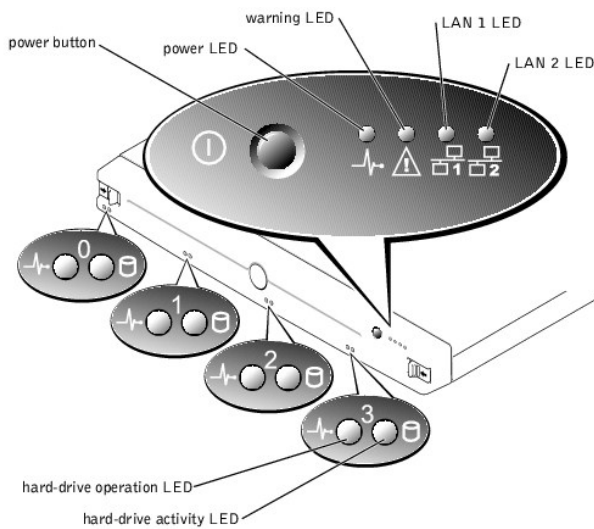

Table 3-1. Front-Panel LED Codes

LED Indicator	Normal Operation	Error Condition
Power	Green	Not applicable.
Warning	Off	Any flash pattern or color indicates a system error. See " System Messages. "
LAN 1 and LAN 2	Steady green indicates the system is connected to the network through the LAN 1 or LAN 2 connector. Flashing green indicates activity between the system and other devices on the network.	Off indicates the system is disconnected from the network or the LAN 1 or LAN 2 connector is not working properly.
Hard drive operation	Green indicates the hard drive is installed in the drive bay and working.	Amber indicates a hard-drive error. While a hard-drive may be inserted in the drive bay, there may be a problem with either the drive or a volume on the drive. The amber/green flash pattern indicates that the RAID for this hard drive is being rebuilt.
Hard drive activity	Flashing amber indicates the hard drive is active.	Not applicable.
		On software RAID systems, solid amber indicates that a software RAID volume has failed.
		On hardware RAID systems, solid amber indicates that a disk has failed.

Back-Panel Indicators

Indicators are on the system's back panel for the 250-W power supply (see [Figure 3-2](#)) and the integrated NICs (see [Figure 3-3](#)). An indicator is not on the 230-W power supply. [Table 3-2](#) details the conditions associated with each back-panel LED indicator code.

Figure 3-2. Power-Supply Indicator (250-W Power Supply Only)

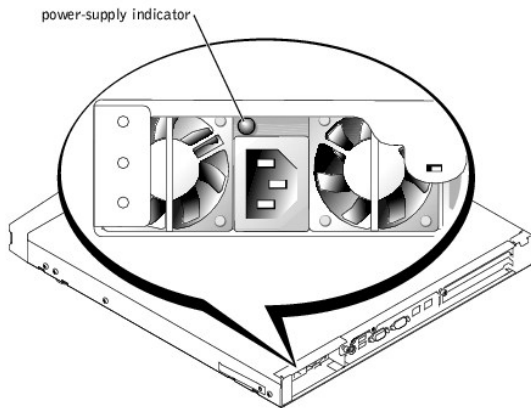

Figure 3-3. NIC Indicators

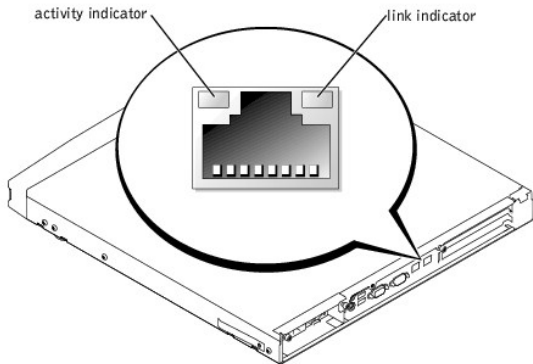

Table 3-2. Back-Panel LED Codes

LED Indicator	Normal Operation	Error Condition
Power supply NOTE: The 230-W power supply does not have an LED indicator.	Steady green indicates that the system is receiving power from a power source and the system is turned on. Blinking green indicates that the system is receiving power, but the system is not turned on.	Steady amber indicates the power supply has either shut down because temperatures or voltages are outside threshold limits, or the power supply has failed. Off indicates that the system is not receiving power from a power source or the power supply has failed.
NIC activity	Flashing green indicates network data is being sent or received.	When off at the same time the link indicator is off, the NIC is not connected to the network.
NIC link	Steady amber indicates that the NIC is connected to a valid link partner on the network.	When off at the same time the activity indicator is off, the NIC is not connected to the network.

System Messages

System messages alert you to a possible hardware problem during system boot.

To view system messages, perform the following steps:

1. Connect a keyboard, mouse, and monitor to the NAS system and enter the System Setup utility by pressing <F2> during system boot.

For information about the System Setup utility, see ["Using the System Setup Utility."](#)

 **NOTE:** While it is recommended that you use a keyboard, mouse, and monitor to access the System Setup utility, you can also use console redirection from a client system connected by serial cable to the NAS system. For more information about using console redirection, see "Using Console Redirection" in the *Installation and Troubleshooting Guide*.

2. From the **Advanced** menu, select **Event Log Configuration**.
3. Select View Event Log and press <Enter>.

 **NOTE:** If the **View Event Log** option is not present, then no event logs are available.

[Table 3-3](#) lists the system error messages and the probable cause for each message.

Table 3-3. System Messages

Message	Cause	Corrective Action
HDD Controller Failure	BIOS cannot communicate with the hard-drive controller.	Check the connections to the hard drive. See "RAID Controller."
CMOS Battery Low	The battery on the system is low or faulty.	Replace the system battery. See "Replacing the Battery." If the problem persists, replace the system board. See "Removing the System Board/Backplane Board Assembly."
CMOS Checksum Bad	The checksum value (CMOS RAM settings) differs from the current value.	In the System Setup utility, select to autoloading the optimal setting. See "Using the System Setup Utility."
CMOS Time and Date Not Set	The BIOS does not have date and time values.	Use the System Setup utility to set the time and date. See "Using the System Setup Utility."
Pri Master HDD error	Primary hard drive is not responding.	Replace the primary hard drive. See "Removing a Hard Drive."
Sec Master HDD error	Secondary hard drive is not responding.	Replace the secondary drive. See "Removing a Hard Drive."
Cache Memory Error	Cache memory is defective.	Disable the cache in the System Setup utility. See "Using the System Setup Utility."

System Beep Codes

When an error occurs during a boot routine that cannot be reported on the screen (either on a monitor connected directly to the NAS system or on a client screen using console redirection), the system may emit a series of beeps to indicate a problem. For example, five beeps indicates a problem with the processor. This information is valuable to technical support representatives if you must call for technical assistance. For more information, see "Using Console Redirection" in the *Installation and Troubleshooting Guide*.

When you hear a beep code, record it, and then look up a description of the problem and corrective action in [Table 3-4](#). If you are unable to resolve the problem using the beep code, use the system diagnostics to identify the cause.

 **NOTE:** If the system boots without a keyboard, mouse, or monitor attached, the system will not issue beep codes related to those peripherals.

Table 3-4. System Beep Codes

Beeps	Cause	Corrective Action
1	The memory refresh circuitry on the system board is faulty.	Replace the system board. See " Removing the System Board/Backplane Board Assembly ."
2	Parity error in the first 64 KB of memory.	Switch memory modules. See " Removing Memory Modules ."
3	Memory failure in the first 64 KB of memory.	Remove and replace the memory modules. If the problem persists, replace the faulty memory modules. See " Memory " for information about replacing memory modules.
4	Memory failure in the first 64 KB of memory, or Timer 1 on the system board is not functioning.	Switch memory modules. See " Memory " for information about replacing memory modules.
5	The processor on the system board has generated an error.	Remove and reseat the processor. See " Processor ." If the problem persists, replace the processor. See " Removing the Processor ."
6	The keyboard controller has generated an error.	Replace the system board. See " Removing the System Board/Backplane Board Assembly ."
7	Processor exception interrupt error. The processor generated an exception interrupt.	Remove and reseat the processor. See " Processor ." If the problem persists, replace the processor. See " Removing the Processor ."
8	Display memory read/write test fails.	Replace the system board. See " Removing the System Board/Backplane Board Assembly ."
9	ROM checksum error.	The ROM checksum value does not match the value encoded in the BIOS. Replace the system board. See " Removing the System Board/Backplane Board Assembly ."
10	CMOS shutdown register read/writer error.	Replace the system board. See " Removing the System Board/Backplane Board Assembly ."
11	External cache is faulty.	Remove and reseat the processor. See " Processor ." If the problem persists, replace the processor. See " Removing the Processor ."

System Board LED Codes

Some LEDs on the system board are visible only when the system cover is removed. A standby power LED (located between DIMM C and the processor blower) provides an indication that the standby 5-V level is present. The LAN1 and LAN2 integrated NICs each have two LEDs behind their connectors on the system board. These LEDs have different meanings than the LEDs on the RJ45 connectors at the external back panel. [Table 3-5](#) lists the system board LED codes and their meanings.

Table 3-5. System Board LED Codes

LED Indicator	Normal Operation	Error Condition
5-V Standby Power	Green	Steady green indicates the 5-V standby power is on. Off indicates the AC power is off.
LAN 1 D1 and D2 LEDs	Green on either LED	Steady green on D1 LED indicates the NIC transmission speed is 1000 Mbps. Steady green on D2 LED indicates the NIC transmission speed is 100 Mbps.
LAN 2 D3 and D4 LEDs	Green on either LED	Steady green on D3 LED indicates the NIC transmission speed is 1000 Mbps. Steady green on D4 LED indicates the NIC transmission speed is 100 Mbps.

NAS Manager Messages

The NAS manager maintains a log file that stores messages, which are sometimes called events or event log entries, generated by an application, service, or operating system. The messages are used to track the operations performed by the system. For information about viewing log files, see your *System Administrator's Guide*.

[Back to Contents Page](#)

[Back to Contents Page](#)

System Overview

Dell™ PowerVault™ 725N Systems Service Manual

- [System Features](#)
 - [Service Features](#)
 - [Supported Operating System](#)
 - [Software Features](#)
 - [Power Protection Devices](#)
 - [Other Documents You May Need](#)
 - [Technical Specifications](#)
-

The Dell™ PowerVault™ 725N network attached storage (NAS) system allows you to easily add storage to a workgroup, small office, or small business network, off loading the file management responsibilities from the server. The NAS system is a "headless" device, meaning it can be managed from any browser. Or, you can connect a keyboard, mouse, and monitor to configure or troubleshoot the system.

This section describes the major hardware and software features of your system, power protection devices, and provides information about other documents you may need when setting up your system.

System Features

- 1 1-U rack-mountable chassis.
 - 1 Intel® Celeron® processor with a speed of at least 1.7 GHz (Celeron) or Intel Pentium® 4 processor with a speed of 2.0 GHz, 2.4 GHz, or 2.6 GHz.
 - 1 Three 64-bit DIMM slots, each supporting at least 128 MB DDR SDRAM.
 - 1 Four hot-pluggable IDE hard drives connected to four IDE master channels in a RAID configuration.
 - 1 One 230-W or 250-W power supply.
 - 1 Three system cooling fans and two power-supply cooling fans.
 - 1 Serial connector used for console redirection. For more information, see "Using Console Redirection" in the *Installation and Troubleshooting Guide*.
 - 1 Two USB ports.
 - 1 Two integrated Broadcom 10/100/1000 BASE-T NICs with RJ45 Ethernet ports.
 - 1 One 64-bit, 133 MHz PCI-X slot, and one 64-bit, 33 MHz PCI slot. Both slots support full-height, half-length cards.
 - 1 Two integrated IDE controllers.
 - 1 Embedded systems management circuitry that monitors operation of the system fans as well as critical system voltages and temperatures. The systems management circuitry works in conjunction with your systems management software.
-

Service Features

The system includes the following service features to make troubleshooting and repair easy and effective:

- 1 PowerVault NAS Manager, which is a Web-based software interface used to monitor and manage the system
 - 1 A temperature monitor that shuts down the system if the temperature exceeds the threshold setting
 - 1 System diagnostics, which checks for hardware problems
 - 1 A chassis and system board that simplifies removing and replacing components
 - 1 Microsoft® Windows® Powered operating system help (available through Windows Terminal Services)
-

Supported Operating System

The system supports the Microsoft Windows Powered operating system.

Software Features

- 1 Microsoft Server Appliance Kit
- 1 Services for UNIX®, Novell® NetWare®, and Macintosh (integrated on the Microsoft Windows Powered operating system)
- 1 Protocol support for TCP/IP, DHCP (client support), DNS (client support), NIS (client support), IPX, and AppleTalk
- 1 Disk management through Dell OpenManage™ Array Manager
- 1 Dell ActiveArchive™ snapshot software
- 1 Diagnostics for evaluating your system's components and devices
For information about using the system diagnostics, see "[Basic Troubleshooting](#)."

Power Protection Devices

Certain devices protect your system from the effects of problems such as power surges and power failures.

- 1 PDU — Uses circuit breakers to ensure that the AC current load does not exceed the PDU's rating.
- 1 Surge protector — Prevents voltage spikes, such as those that may occur during an electrical storm, from entering the system through the electrical outlet. Surge protectors do not provide protection from brownouts, which occur when the voltage drops more than 20 percent below the normal AC line voltage level.
- 1 Line conditioner — Maintains a system's AC power source voltage at a moderately constant level and provides protection from brownouts, but does not protect against a complete power loss.
- 1 UPS — Uses battery power to keep the system running when AC power is unavailable. The battery is charged by AC power while it is available so that after AC power is lost, the battery can provide power to the system for a limited amount of time—from 15 minutes to approximately an hour. A UPS that provides only 5 minutes of battery power allows you to shutdown the system. Use surge protectors and PDUs with all universal power supplies, and ensure that the UPS is UL-safety approved.

Other Documents You May Need

 The *System Information Guide* provides important safety and regulatory information. Warranty information may be included within this document or as a separate document.

- 1 The *Rack Installation Guide* included with your rack solution describes how to install your system into a rack.
- 1 The *Setting Up Your System* document provides an overview of initially setting up your system.
- 1 The *User's Guide* provides information about system features and technical specifications.
- 1 The *Installation and Troubleshooting Guide* describes how to troubleshoot the system and install or replace system components.
- 1 The *System Administrator's Guide* provides system configuration, operation, and management information.
- 1 Systems management software documentation describes the features, requirements, installation, and basic operation of the software.
- 1 Documentation for any components you purchased separately provides information to configure and install these options.
- 1 Updates are sometimes included with the system to describe changes to the system, software, and/or documentation.

 **NOTE:** Always read the updates first because they often supersede information in other documents.

- 1 Release notes or readme files may be included to provide last-minute updates to the system or documentation or advanced technical reference material intended for experienced users or technicians.

Technical Specifications

Processor	
Processor type	Intel Celeron processor with a speed of at least 1.7 GHz or Intel Pentium 4 processor with a speed of 2.0 GHz, 2.4 GHz, or 2.6 GHz

Expansion Bus	
Bus type	one PCI and one PCI-X
Expansion slots	one PCI 64-bit, 33 MHz and one PCI-X 64-bit, 133 MHz

Memory	
Architecture	PC-2100 SDRAM
Memory module sockets	three DIMM sockets
Memory module capacities	at least 128-MB registered DDR SDRAM DIMMs
Minimum RAM	384 MB

Drives	
Hard drives	four 1-inch, internal IDE hard drives, each with capacities of not less than 40 GB

Ports and Connectors	
Externally accessible:	
Serial	one 9-pin connector; UART 6550-compatible
USB	two 4-pin connectors
NIC	two RJ45 connector for integrated 10/100/1000 NICs
PS/2 style keyboard	6-pin mini-DIN connector
PS/2-compatible mouse	6-pin mini-DIN connector
Video	one 15-pin connector

Video	
Video type	ATI Rage XL PCI video controller; VGA connector
Video memory	8 MB

Power	
Power supply:	
Wattage	250 W or 230W
Voltage	100–240 VAC, 50–60 Hz
Output hold up time	20 ms minimum
Maximum inrush current	under typical line conditions and over the entire system ambient operating range, the inrush current may reach 30 A per power supply for 10 ms or less
System battery	3.0-V lithium ion coin cell

Physical	
Rack:	
Height	4.2 cm (1.66 inches)
Width	42.7 cm (16.8 inches)
Depth	58.4 cm (23 inches)
Weight	12.27 kg (27 lb), maximum configuration

Environmental	
Temperature:	
Operating	10°C to 35°C (50°F to 95°F) at 10,000 feet above sea level 10°C to 40°C (50°F to 104°F) at sea level
Storage	-40°C to 65°C (-40°F to 149°F)
Relative humidity:	

Operating	20% to 80% (noncondensing)
Storage	5% to 95% (noncondensing)
Maximum vibration:	
Operating:	0.25 G at 3 to 200 Hz for 15 minutes
Storage:	0.50 G at 3 to 200 Hz for 15 minutes
Maximum shock:	
Operating	one shock pulse in the positive and negative x, y, and z axes (one pulse on each side of the system) of 31 G for up to 2 ms
Storage (non-operational)	six consecutively executed shock pulses in the positive and negative x, y, and z axes (one pulse on each side of the system) of 71 G for up to 2 ms
Altitude:	
Operating	-16 to 3,048 m (-50 to 10,000 ft.)
Storage	-16 to 10,600 m (-50 to 35,000 ft.)

[Back to Contents Page](#)

Jumpers and Connectors

Dell™ PowerVault™ 725N Systems Service Manual

- [Jumpers—A General Explanation](#)
- [System Board Jumpers](#)
- [System Board Connectors](#)
- [Riser-Card Connectors](#)
- [Backplane Board Connectors](#)

This section provides specific information about the system jumpers. It also provides some basic information on jumpers and switches and describes the connectors on the various boards in the system.

Jumpers—A General Explanation

Jumpers provide a convenient and reversible way of reconfiguring the circuitry on a printed circuit board. When reconfiguring the system, you may need to change jumper settings on circuit boards or drives.

Jumpers

Jumpers are small blocks on a circuit board with two or more pins emerging from them. Plastic plugs containing a wire fit down over the pins. The wire connects the pins and creates a circuit. To change a jumper setting, pull the plug off its pin(s) and carefully fit it down onto the pin(s) indicated. [Figure 5-1](#) shows an example of a jumper.

Figure 5-1. Example Jumpers

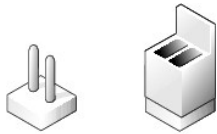

⚠ CAUTION: Ensure that the system is turned off before you change a jumper setting. Otherwise, damage to the system or unpredictable results may occur.

A jumper is referred to as open or unjumped when the plug is pushed down over only one pin or if there is no plug at all. When the plug is pushed down over two pins, the jumper is referred to as jumped. The jumper setting is often shown in text as two numbers, such as 1-2. The number 1 is printed on the circuit board so that you can identify each pin number based on the location of pin 1.

[Figure 5-2](#) shows the location and default settings of the system jumper blocks. See [Table 5-1](#) for the designations, default settings, and functions of the system's jumpers.

System Board Jumpers

[Figure 5-2](#) shows the location of the configuration jumpers on the system board. [Table 5-1](#) lists the jumpers settings.

Figure 5-2. System Board Jumpers

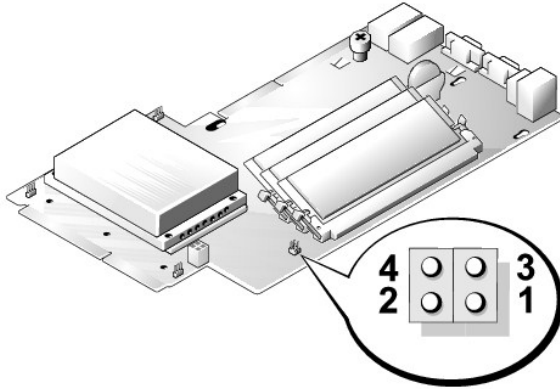







Table 5-1. System Board Jumper Settings

Jumper	Setting	Description
PASSWD pins 1 and 2		The password feature is disabled.
	 (default)	The password feature is enabled.
NVRAM_CLR pins 3 and 4	 (default)	The configuration settings are retained at system boot.
		The configuration settings are cleared at next system boot. (If the configuration settings become corrupted to the point where the system will not boot, install the jumper and boot the system. Remove the jumper before restoring the configuration information.)
 jumpered	unjumpered	

System Board Connectors

See Figure 5-3 and Table 5-2 for the location and description of system board connectors.

Figure 5-3. System Board Connectors

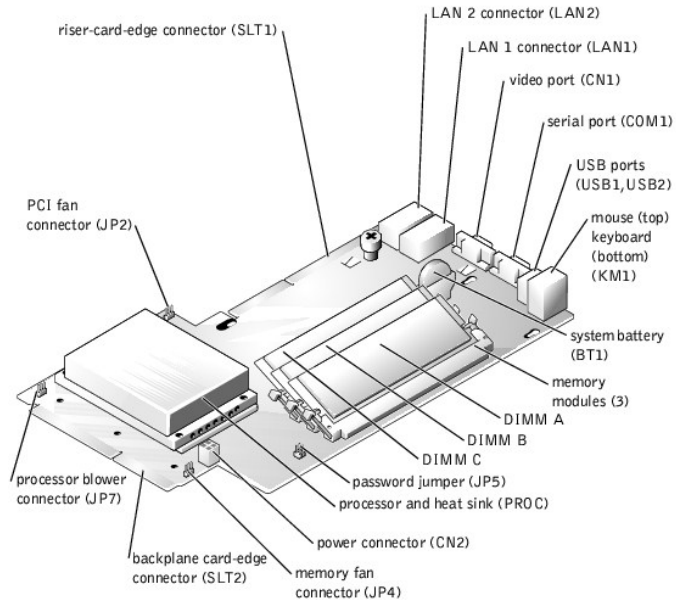

Table 5-2. System Board Connectors

Connector	Description
BT1	System battery
CN1	Video port CN1
CN2	Power connector
COM1	Serial port COM1
DIMM_x	Memory modules (3), where x is the slot in the bank
JP2	PCI fan connector
JP4	Memory fan connector
JP5	Password jumper
JP7	Processor blower assembly
KM1	Mouse connector (top), keyboard connector (bottom)
LAN1, LAN2	LAN connectors (2)
PROC	Processor and heat sink
SLT1	Riser card-edge connector
SLT2	Backplane card-edge connector
USB1, USB2	USB ports

Riser-Card Connectors

The riser card has two expansion card connectors on the back side and a single connector for connecting to the card-edge connector on the system board. See [Figure 5-4](#) and [Table 5-3](#) for the location of riser-card connectors.

Figure 5-4. Riser-Card Connectors

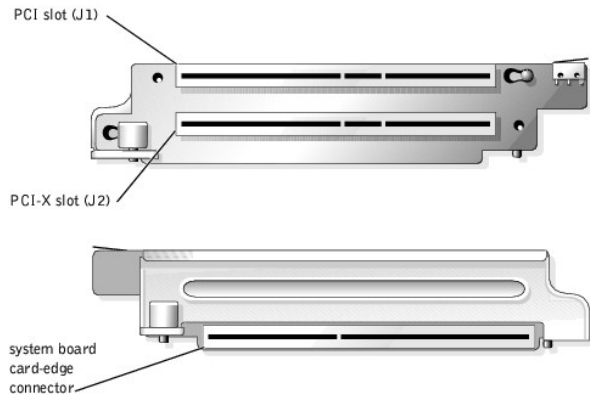

Table 5-3. Riser Board Connectors

Connector	Description
J1	PCI expansion card slots on riser card
J2	PCI-X expansion card slots on riser card
card-edge	Connector to system board card-edge connector SLT1. See Figure 5-3 .

Backplane Board Connectors

[Figure 5-5](#) shows the location of the connectors on the backplane board.

Figure 5-5. Backplane Board Connectors

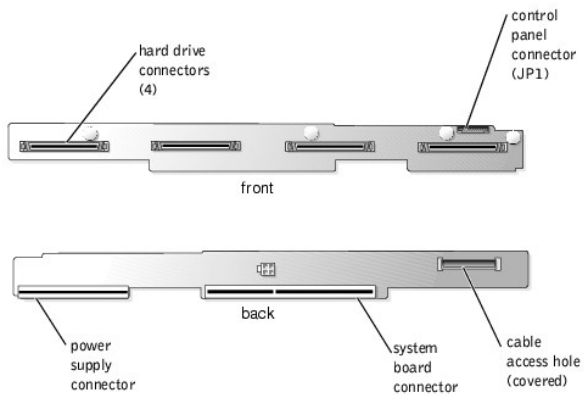



[Back to Contents Page](#)

Dell™ PowerVault™ 725N Systems Service Manual

• [Notes, Notices, and Cautions](#)

Notes, Notices, and Cautions

-  **NOTE:** A NOTE indicates important information that helps you make better use of your computer.
-  **NOTICE:** A NOTICE indicates either potential damage to hardware or loss of data and tells you how to avoid the problem.
-  **CAUTION:** A CAUTION indicates a potential for property damage, personal injury, or death.

Information in this document is subject to change without notice.
© 2003 Dell Inc. All rights reserved.

Reproduction in any manner whatsoever without the written permission of Dell Inc. is strictly forbidden.

Trademarks used in this text: *Dell*, the *DELL* logo, *PowerVault*, *Dell ActiveArchive*, and *Dell OpenManage* are trademarks of Dell Inc.; *Intel*, *Pentium*, and *Celeron* are registered trademarks of Intel Corporation; *Novell* and *NetWare* are registered trademarks of Novell, Inc.; *Microsoft*, *Windows*, *Windows NT* and *MS-DOS* are registered trademarks of Microsoft Corporation; *UNIX* is a registered trademark of The Open Group in the United States and other countries; *VESA* is a registered trademark of Video Electronics Standards Association.

Other trademarks and trade names may be used in this document to refer to either the entities claiming the marks and names or their products. Dell Inc. disclaims any proprietary interest in trademarks and trade names other than its own.

[Back to Contents Page](#)

[Back to Contents Page](#)

Removing and Replacing Parts

Dell™ PowerVault™ 725N Systems Service Manual

- [Recommended Tools](#)
- [Front Panel](#)
- [System Cover](#)
- [Inside the System](#)
- [Control Panel](#)
- [Fan Assemblies](#)
- [Power Supply](#)
- [Riser Card](#)
- [Expansion Cards](#)
- [RAID Controller](#)
- [Hard Drives](#)
- [Backplane Board](#)
- [Memory](#)
- [Processor](#)
- [System Battery](#)
- [System Board and Backplane Board](#)

The procedures in this guide require that you remove the cover and work inside the system. While working inside the system, do not attempt to service the system except as explained in this manual and elsewhere in your system documentation. Always follow the instructions closely. Review all of the procedures in your *System Information Guide*.

⚠ CAUTION: See your *System Information Guide* for complete information about safety precautions, working inside the computer, and protecting against electrostatic discharge.

This section provides servicing procedures for components inside the system. Before you start any of the procedures in this section, perform the following tasks:

⚠ Read the safety information in the *System Information Guide*.

- 1 Perform the procedures described in "[External Visual Inspection](#)."

When a replacement procedure is not provided, use the removal procedure in reverse order to install the replacement part.

Recommended Tools

You need the following items to perform the procedures in this section:

- 1 Key to the system keylock
 - 1 #2 Phillips screwdriver
 - 1 Wrist grounding strap
-

Front Panel

To access the hard drives, you must first remove the system's front panel.

Removing the Front Panel

To remove the front panel, push the front panel latches inward and pull the panel away from the system. See [Figure 4-1](#).

Figure 4-1. Removing the Front Panel

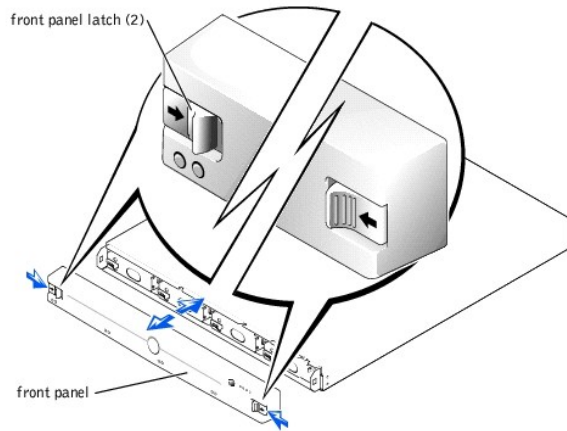

Replacing the Front Panel

To replace the front panel, push the latches inward, place the panel on the front of the system and release the latches.

System Cover

To add or replace internal system components or troubleshoot the system, you must first remove the system cover to access components.

Removing the System Cover

⚠ CAUTION: See your *System Information Guide* for complete information about safety precautions, working inside the computer, and protecting against electrostatic discharge.

1. Unscrew the thumbscrew at the back of the system. See [Figure 4-2](#).
2. Slide the system cover backward about an inch, and grasp the cover on both sides.
3. Carefully lift the cover away from the system.

Figure 4-2. Removing the System Cover

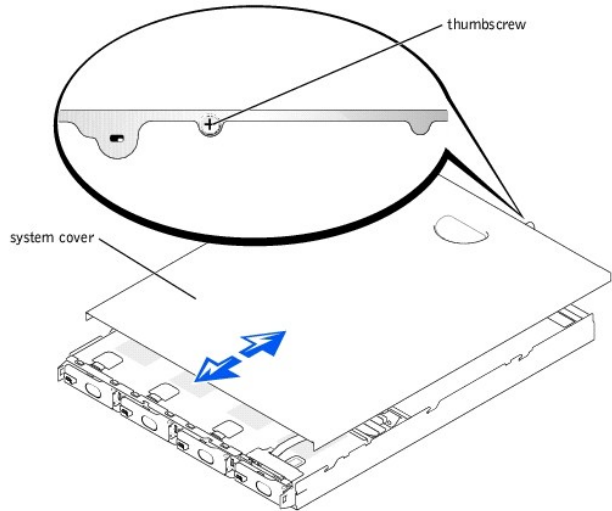

Replacing the System Cover

1. Ensure that you did not leave tools or parts inside the system.
2. Place the cover over the sides of the chassis, and slide the cover forward until it snaps into place. See [Figure 4-2](#).
3. Tighten the thumbscrew at the back of the system to secure the cover.

Inside the System

In [Figure 4-3](#), the system cover and front panel are removed to provide an interior view of the system.

Figure 4-3. Inside the System

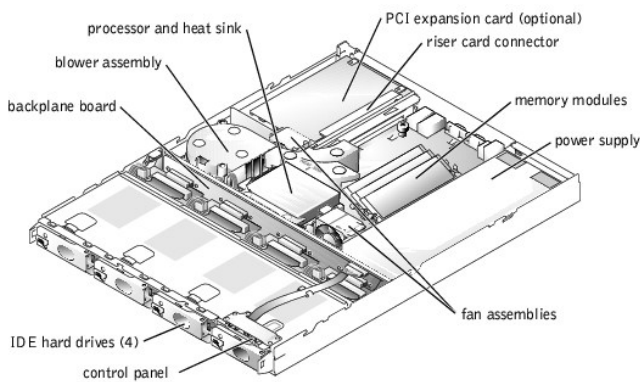

The system board holds the system's control circuitry and other electronic components. Several hardware options such as the processors and memory are installed directly on the system board. The system board can accommodate two PCI expansion cards.

The hard-drive bays provide space for up to four IDE hot-plug drives. Power is supplied to the backplane board, the system board, and internal peripherals through a power supply.

Control Panel

⚠ CAUTION: See your *System Information Guide* for complete information about safety precautions, working inside the computer, and protecting against electrostatic discharge.

In [Figure 4-4](#), the control panel is shown removed from the system chassis.

Figure 4-4. Control-Panel Removal

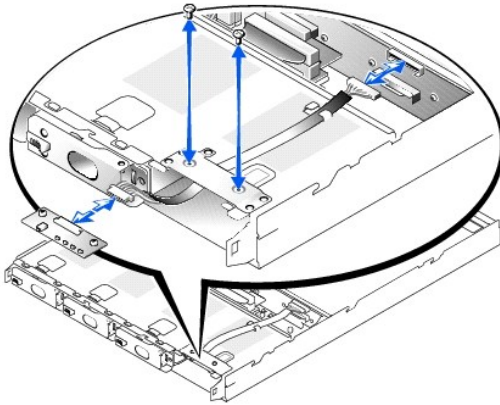

Removing the Control Panel

⚠ CAUTION: See your *System Information Guide* for complete information about safety precautions, working inside the computer, and protecting against electrostatic discharge.

1. Remove the front panel. See "[Removing the Front Panel](#)."
2. Remove the system cover. See "[Removing the System Cover](#)."
3. Remove the right-most hard drive. See "[Removing a Hard Drive](#)."
4. Disconnect the control panel cable from the backplane board.
5. Remove the two retaining screws that secure the control-panel to the system chassis. See [Figure 4-4](#).
6. Disconnect the control panel cable from the control panel.
7. Remove the control panel from the system chassis. See [Figure 4-4](#).

Installing the Control Panel

⚠ CAUTION: See your *System Information Guide* for complete information about safety precautions, working inside the computer, and protecting against electrostatic discharge.

1. Connect the control-panel cable to the control panel. See [Figure 4-4](#).
2. Position the control panel inside the hard-drive slot and secure it with the two screws you removed in [step 5](#) of the procedure, "[Removing the Control Panel](#)."
3. Connect the control-panel cable to the backplane. See [Figure 4-4](#).

Fan Assemblies

The blower assembly, which is located behind IDE drive 1, contains one fan. In addition, two smaller fan assemblies are inside: one located near the processor and heat sink.

Removing a Blower or Fan Assembly

CAUTION: Before you perform this procedure, you must turn off the system and disconnect it from the power source.

CAUTION: See your *System Information Guide* for complete information about safety precautions, working inside the computer, and protecting against electrostatic discharge.

NOTICE: When you turn off the system, press the power button for less than 2 seconds. If you press the power button for longer than 3 seconds, the system will automatically rebuild the RAID arrays the next time the system is turned on. This could impact system performance for several hours.

1. Turn off the system and attached peripherals, and disconnect the system from the electrical outlet.
2. Remove the system cover. See "[Removing the System Cover](#)."
3. Lift the blower or fan assembly out of the chassis carefully, making sure that the connector disconnects from the system board. See [Figure 4-5](#) (processor blower assembly) and [Figure 4-6](#) (memory fan assembly) and [Figure 4-7](#) (PCI fan assembly).

Figure 4-5. Removing the Processor Blower Assembly

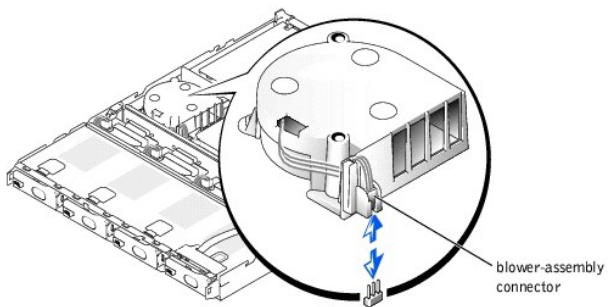

Figure 4-6. Removing the Memory Fan Assembly

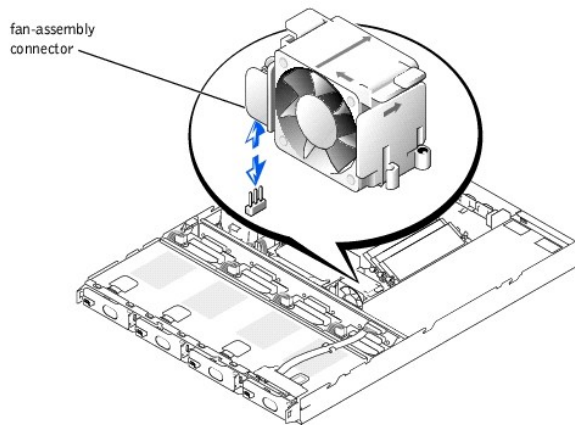
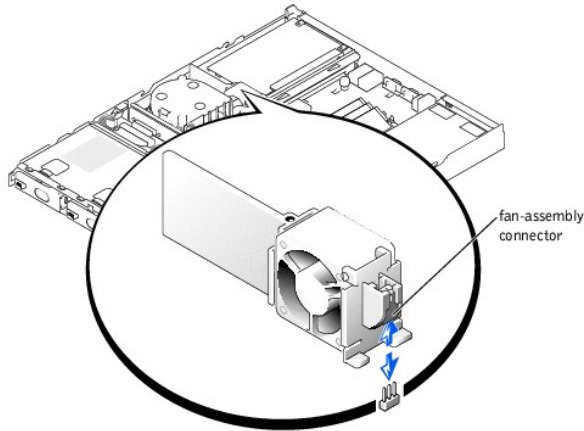

Figure 4-7. Removing the PCI Fan Assembly



Replacing a Blower or Fan Assembly

⚠ CAUTION: See your *System Information Guide* for complete information about safety precautions, working inside the computer, and protecting against electrostatic discharge.

1. Align the replacement blower or fan assembly with the connector on the system board and the pegs on the chassis.
2. Push down on the blower or fan assembly until it is properly seated on the chassis pegs.
3. Attach the blower or fan assembly connector to the three-pin connector on the system board.
4. Replace the system cover. See "[Replacing the System Cover.](#)"
5. Reconnect the system and peripherals to their electrical outlets, and turn them on.

🔧 NOTE: When you turn on the system, press the power button for *less than* two seconds. If you press the power button for longer than 3 seconds, the NAS system shuts down.

Power Supply

The system has a single 250-W or 230-W power supply located behind IDE hard drive 3.

Removing the Power Supply

⚠ CAUTION: See your *System Information Guide* for complete information about safety precautions, working inside the computer, and protecting against electrostatic discharge.

To replace a failed power supply, perform the following steps:

- 🔄 NOTICE:** When you turn off the system, press the power button for less than 2 seconds. If you press the power button for longer than 3 seconds, the system will automatically rebuild the RAID arrays the next time the system is turned on. This could impact system performance for several hours.
1. Turn off the system and attached peripherals, and disconnect the system from the electrical outlet.
 2. Remove the system cover. See "[Removing the System Cover.](#)"
 3. Pull up to remove the plastic insert that secures the power supply inside the system. See [Figure 4-9](#).
 4. If you are removing a 230-W power supply, perform the following steps. Otherwise, go to [step 5](#).
 - d. Disconnect the power-supply cable from the converter board. See [Figure 4-8](#).
 - e. Grasp the front of the power supply, push it toward the back of the system, and lift it out of the chassis.
 - f. Remove the two screws on the converter board, slide the board toward the back of the system about 1 cm (0.5 inch), and lift it off the guide pins and out of the chassis.
 5. If you are removing a 250-W power supply, grasp the front of the power supply push it back toward the back of the system, disengaging it from the backplane connector. See [Figure 4-9](#).

Figure 4-8. Removing and Replacing the 230-W Power Supply

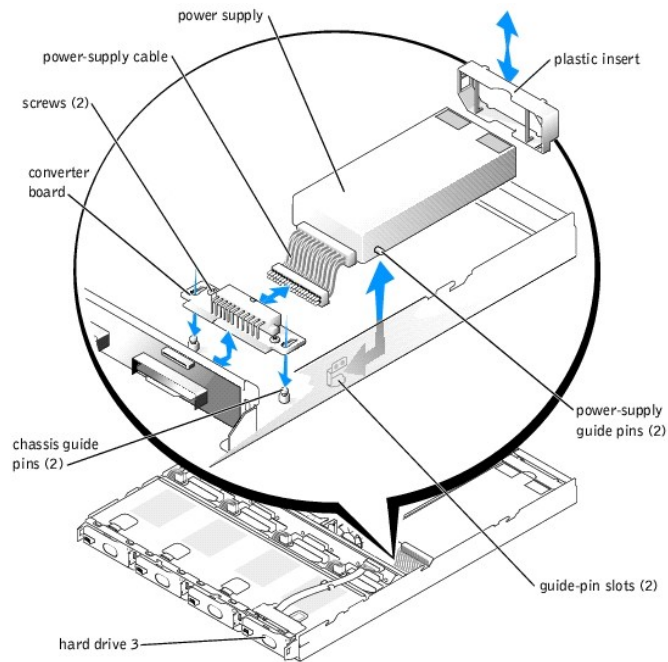
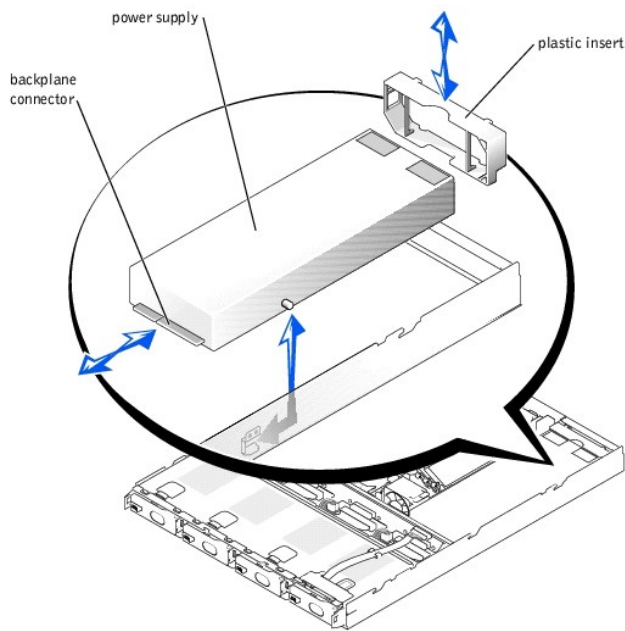

Figure 4-9. Removing and Replacing the 250-W Power Supply



Installing the Power Supply

CAUTION: See your *System Information Guide* for complete information about safety precautions, working inside the computer, and protecting against electrostatic discharge.

1. To install the replacement power supply, insert the rear guide pins on the power supply into the guide-pin slots on the chassis, lower the power supply

into the chassis, and then push the power supply toward the front of the system until the connector is firmly seated in the backplane.

2. Replace the plastic insert removed in [step 3](#) of the procedure, "[Removing the Power Supply](#)."
3. Replace the system cover (see "[Replacing the System Cover](#)") and then reconnect the system and peripherals to the power source and turn on the system.

NOTE: When you turn on the system, press the power button for *less than* two seconds. If you press the power button for longer than 3 seconds, the NAS system shuts down.

Riser Card

The riser card provides two slots for PCI/PCI-X expansion cards.

Removing the Riser Card

CAUTION: See your *System Information Guide* for complete information about safety precautions, working inside the computer, and protecting against electrostatic discharge.

NOTICE: When you turn off the system, press the power button for less than 2 seconds. If you press the power button for longer than 3 seconds, the system will automatically rebuild the RAID arrays the next time the system is turned on. This could impact system performance for several hours.

1. Turn off the system and attached peripherals, and disconnect the system from the electrical outlet.
2. Remove the system cover. See "[Removing the System Cover](#)."
3. Remove the expansion cards installed in the riser card. See "[Removing an Expansion Card](#)." PCI 1 slot is on top and the PCI 2 slot is on bottom.
4. Loosen the two thumbscrews that secure the riser card to the system board. See [Figure 4-10](#).
5. From the back of the system chassis, slide the riser card to the right and lift the riser card up and out of the chassis.

Figure 4-10. Removing the Riser Card

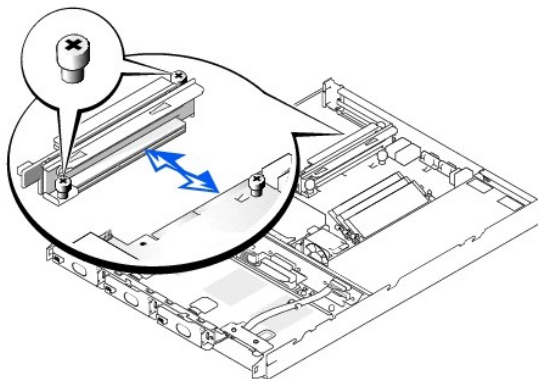

Installing the Riser Card

CAUTION: See your *System Information Guide* for complete information about safety precautions, working inside the computer, and protecting against electrostatic discharge.

1. Slide the replacement riser card onto the connector on the side of the system board.
2. Secure the riser card with its two thumbscrews.
3. Install the expansion cards into their slots on the riser card. See "[Installing an Expansion Card](#)."
4. Replace the system cover, and then reconnect the system and peripherals to the power source and turn on the system.

NOTE: When you turn on the system, press the power button for *less than* two seconds. If you press the power button for longer than 3 seconds, the NAS system shuts down.

Expansion Cards

The system supports up to two PCI expansion cards, which are installed in connectors on a riser board at the back of the system.

CAUTION: See your *System Information Guide* for complete information about safety precautions, working inside the computer, and protecting against electrostatic discharge.

Installing an Expansion Card

1. Turn off the system and attached peripherals, and disconnect the system from the electrical outlet.
2. Remove the system cover. See "[Replacing the System Cover](#)."
3. Remove the plastic insert adjacent to the expansion card slots and then remove the filler bracket on the slot you will be using. See [Figure 4-11](#). The PCI 1 slot is on top and the PCI 2 slot is on bottom.

NOTE: Keep this bracket in the event you need to remove the expansion card. Filler brackets must be installed over empty expansion card slots to maintain Federal Communications Commission (FCC) certification of the system. The brackets also keep dust and dirt out of the system and help keep the system properly cooled by promoting airflow inside the system.

4. Insert the expansion card firmly into the expansion-card connector on the riser board until the card is fully seated, being careful not to remove the riser card from the system board.
5. Replace the plastic insert, ensuring that the insert is oriented exactly as shown in [Figure 4-11](#).
6. Connect the expansion-card cable to the external expansion card connector.
7. Replace the system cover, and then reconnect the system and peripherals to the power source and turn on the system.

NOTE: When you turn on the system, press the power button for *less than* two seconds. If you press the power button for longer than 3 seconds, the NAS system shuts down.

Figure 4-11. Installing an Expansion Card

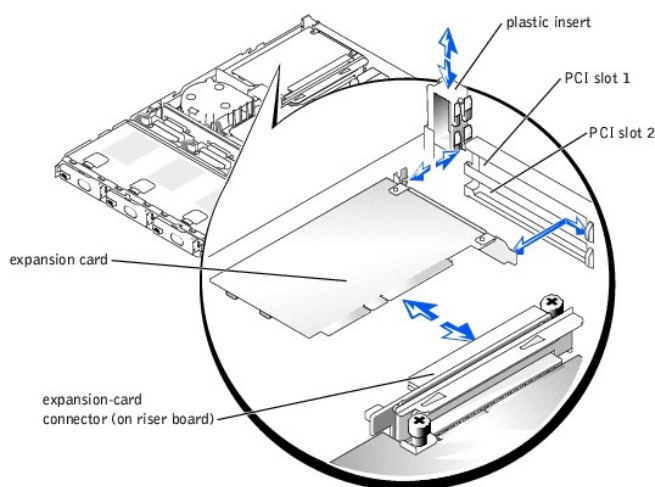

Removing an Expansion Card

CAUTION: See your *System Information Guide* for complete information about safety precautions, working inside the computer, and protecting against electrostatic discharge.

1. Turn off the system and attached peripherals, and disconnect the system from the electrical outlet.

2. Remove the system cover. See "[Removing the System Cover.](#)"
3. Disconnect any cables connected to the expansion card.
4. Remove the plastic insert adjacent to the expansion card slots. See [Figure 4-11.](#)
5. Grasp the expansion card and carefully pull it away from the riser-card connector.
6. If you are permanently removing the card, replace the metal filler bracket over the empty card-slot opening.

NOTE: Filler brackets must be installed over empty expansion card slots to maintain Federal Communications Commission (FCC) certification of the system. The brackets also keep dust and dirt out of the system and help keep the system properly cooled by promoting airflow inside the system.

7. Replace the plastic insert, ensuring that the insert is oriented exactly as shown in [Figure 4-11.](#)
8. Replace the system cover. See "[Replacing the System Cover.](#)"
9. Reconnect the system and peripherals to the power source and turn on the system.

NOTE: When you turn on the system, press the power button for *less than* two seconds. If you press the power button for longer than 3 seconds, the NAS system shuts down.

RAID Controller

The Cost Effective RAID Controller (CERC) card is a half-length PCI adapter card that provides four master RAID-capable IDE channels. The card is available only as a pre-installed option on some NAS systems.

CAUTION: See your *System Information Guide* for complete information about safety precautions, working inside the computer, and protecting against electrostatic discharge.

Replacing the RAID Controller

1. Turn off the system and attached peripherals, and disconnect the system from the electrical outlet.
2. Remove the cover. See "[Removing the System Cover.](#)"
3. Remove the blower and fan assembly. See "[Removing a Blower or Fan Assembly.](#)"
4. Remove the plastic insert adjacent to the expansion slots. See [Figure 4-12.](#)

Figure 4-12. Removing the Plastic Insert

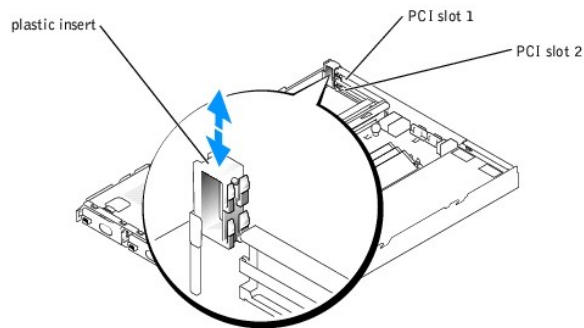

5. Grasp the expansion card and carefully pull it away from the riser-card connector. See [Figure 4-13.](#)

Figure 4-13. Installing the CERC Card

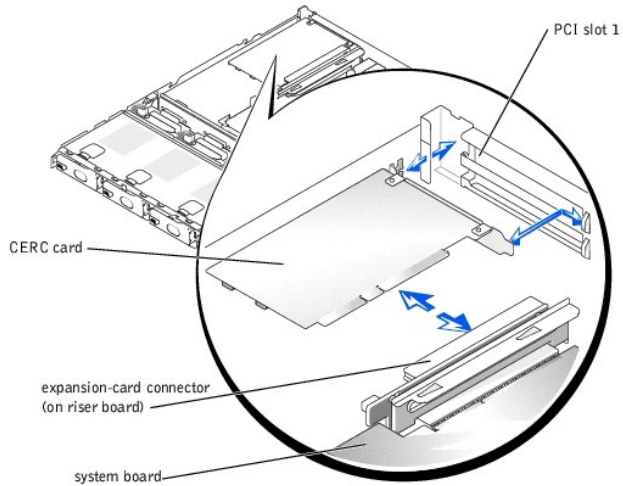

6. Disconnect the cable from the CERC card.
7. Connect the cable that was supplied with the replacement CERC card to the four connectors on the bottom of the replacement card in the order shown in [Figure 4-14](#).
8. Route the CERC card's cable between the guide tabs and the side of the chassis as you lower the card into the system. See [Figure 4-14](#).

Figure 4-14. Connecting and Routing the CERC Card Cable

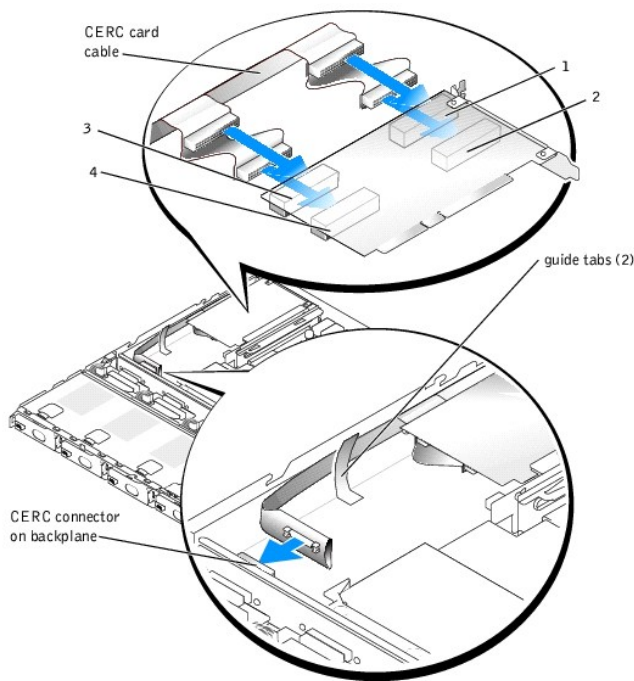

9. Insert the CERC card firmly into the expansion-card connector on the riser board until the card is fully seated, being careful not to disconnect the riser board from the system board. See [Figure 4-13](#).
10. Place the bottom edge of the cable into the guide slot directly under the connector on the left side of the backplane (as viewed from the front of the system), and then attach the cable to the connector on the backplane. See [Figure 4-14](#).
11. Replace the plastic insert adjacent to the expansion slots. See [Figure 4-12](#).
12. Replace the blower and fan assemblies. See "[Replacing a Blower or Fan Assembly](#)."
13. Replace the system cover. See "[Replacing the System Cover](#)."
14. Reconnect the system and peripherals to the electrical outlet and turn on the system.

Hard Drives

Your system comes with four hot-plug IDE hard drives. While hard drives can be removed and installed with the system turned on, the RAID set may need to be updated. For more information, see your *System Administrator's Guide*.

 **NOTE:** Ensure that you use the correct carrier. Hardware RAID drive carriers and software RAID drive carriers are not interchangeable. A label on the bottom of the carrier indicates if the carrier is used for a hardware or software RAID system.

Removing a Hard Drive

 **CAUTION:** See your *System Information Guide* for complete information about safety precautions, working inside the computer, and protecting against electrostatic discharge.

To remove a hard drive, perform the following steps:

1. Remove the front panel. See "[Removing the Front Panel](#)."
2. Push the release lever to the right. See [Figure 4-15](#).
3. Open the latch and use it to pull the drive carrier out of the drive bay.
4. Remove the screws on the bottom of the carrier and remove the drive from the carrier. See [Figure 4-16](#).

 **NOTE:** Do not remove rubber grommets.

Figure 4-15. Releasing the Hard-Drive Latch

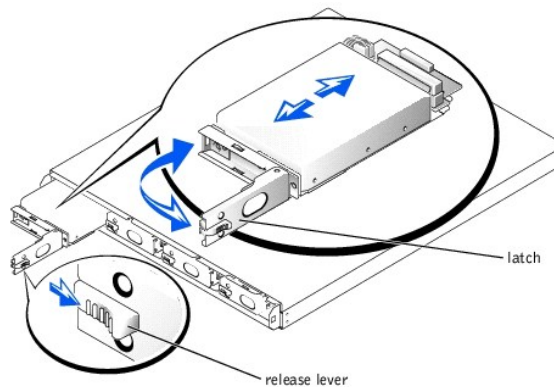
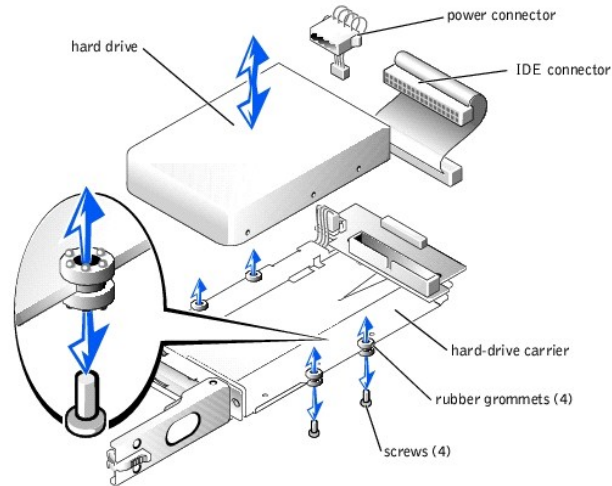

Figure 4-16. Removing the Hard Drive From the Drive Carrier



Installing a Hard Drive

⚠ CAUTION: See your *System Information Guide* for complete information about safety precautions, working inside the computer, and protecting against electrostatic discharge.

To install a replacement hard drive, perform the following steps:

1. Disconnect the drive carrier's power and IDE cables from the drive.
2. Connect the power and IDE cables to the new drive.
3. Place the drive back in the carrier and reattach the screws that you removed in [step 4](#) in "[Removing a Hard Drive](#)."
4. Insert the carrier, with the latch open, into the system.
5. Push the carrier into the drive bay until it is fully seated in the backplane connector.
6. Close the latch.
7. Replace the front panel.

If it is necessary to reinstall your operating system, see your *System Administrator's Guide*.

Backplane Board

See "[System Board and Backplane Board](#)" for removal and replacement procedures. The system board and the backplane board are removed from the system chassis as a single assembly, and then separated.

Memory

⚠ CAUTION: See your *System Information Guide* for complete information about safety precautions, working inside the computer, and protecting against electrostatic discharge.

The three memory module sockets are located on the system board adjacent to the power supply. See [Figure 4-17](#).

You can upgrade the system memory by installing combinations of registered memory modules. If you receive an error message stating that maximum memory has been exceeded, see "[Indicators, Messages, and Codes](#)" for more information. You can purchase memory upgrade kits from Dell.

 **NOTE:** The memory modules must be PC-2100 compliant. For technical specifications on memory modules, see ["Technical Specifications."](#)

Installing Memory Modules

 **NOTICE:** When you turn off the system, press the power button for less than 2 seconds. If you press the power button for longer than 3 seconds, the system will automatically rebuild the RAID arrays the next time the system is turned on. This could impact system performance for several hours.

1. Turn off the system and attached peripherals, and disconnect the system from the electrical outlet.
2. Remove the system cover. See ["Removing the System Cover."](#)
3. Locate the memory module sockets in which you want to install or replace the memory module(s). See [Figure 4-3.](#)
4. Press the ejectors on the memory module socket down and out, as shown in [Figure 4-17](#), to allow the memory module to be inserted into the socket.
5. Align the memory module's edge connector with the alignment keys of the memory module socket, and insert the memory module in the socket.

 **NOTE:** The memory module socket has two alignment keys that allow you to install the memory module in the socket in only one way.

6. Press down on the memory module with your thumbs while pulling up on the ejectors with your index fingers to lock the memory module into the socket.

When the memory module is properly seated in the socket, the ejectors on the memory module socket align with the ejectors on the other sockets that have memory modules installed.

7. Repeat step 3 through step 6 of this procedure to install the remaining memory modules.
8. Replace the system cover, and then reconnect the system and peripherals to the power source and turn on the system.

 **NOTE:** When you turn on the system, press the power button for *less than* two seconds. If you press the power button for longer than 3 seconds, the NAS system shuts down.

9. (Optional) Press <F2> to enter the System Setup utility, and check the **System Memory** setting on the main setup screen.

The system should have already changed the value to reflect the newly-installed memory.

If the value is incorrect, one or more of the memory modules may not be installed properly.

10. Repeat step 1 through step 8 of this procedure, checking to ensure that the memory modules are firmly seated in their sockets.
11. Run the system memory test in the System Diagnostics. See ["Running the System Diagnostics."](#)

Figure 4-17. Installing and Removing a Memory Module

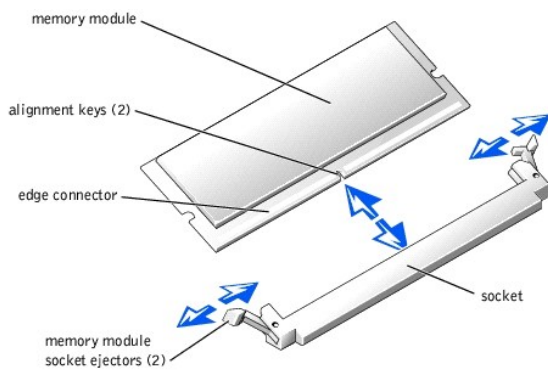

Removing Memory Modules

 **CAUTION:** See your *System Information Guide* for complete information about safety precautions, working inside the computer, and protecting against electrostatic discharge.

 **NOTICE:** When you turn off the system, press the power button for less than 2 seconds. If you press the power button for longer than 3 seconds, the system will automatically rebuild the RAID arrays the next time the system is turned on. This could impact system performance for several hours.

1. Turn off the system and attached peripherals, and disconnect the system from the electrical outlet.
2. Remove the system cover. See "[Removing the System Cover.](#)"
3. Locate the memory module sockets from which you want to remove the memory module(s). See [Figure 4-3.](#)
4. Press down and out on the ejectors on each end of the socket until the memory module pops out of the socket. See [Figure 4-17.](#)
5. Replace the system cover, and then reconnect the system and peripherals to the power source and turn on the system.

 **NOTE:** When you turn on the system, press the power button for *less than* two seconds. If you press the power button for longer than 3 seconds, the NAS system shuts down.

Processor

 **CAUTION:** See your *System Information Guide* for complete information about safety precautions, working inside the computer, and protecting against electrostatic discharge.

It is possible to upgrade your processor to take advantage of future options in speed and functionality. Each processor and its associated Level 2 (L2) cache memory are contained in a pin grid array (PGA) package that is installed in a ZIF socket on the system board.

The following items are included in the processor upgrade kit:

- 1 Processor
- 1 Heat sink
- 1 Securing clip

Removing the Processor

 **CAUTION:** See your *System Information Guide* for complete information about safety precautions, working inside the computer, and protecting against electrostatic discharge.

 **NOTICE:** When you turn off the system, press the power button for less than 2 seconds. If you press the power button for longer than 3 seconds, the system will automatically rebuild the RAID arrays the next time the system is turned on. This could impact system performance for several hours.

1. Turn off the system and attached peripherals, and disconnect the system from the electrical outlet.
2. Remove the system cover. See "[Removing the System Cover.](#)"

 **NOTICE:** The processor and heat sink can become extremely hot. Be sure the processor has had sufficient time to cool before handling.

3. Remove the cooling shroud.
4. Pushing down with one hand on the securing clip's rubber-coated tab, use the other hand to pull the latch on the securing clip on the left to release the securing clip from the heat-sink posts. See [Figure 4-18.](#)
5. Remove the securing clip.

 **NOTICE:** Never remove the heat sink from a processor unless you intend to remove the processor. The heat sink is necessary to maintain proper thermal conditions.

6. Repeat [step 4](#) and [step 5](#) to remove the securing clip on the right.

Figure 4-18. Removing the Securing Clip

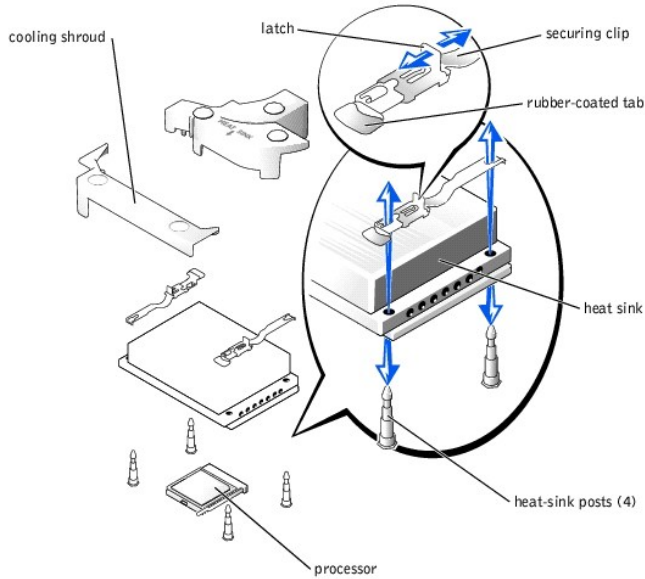

7. Remove the heat sink.
8. Pull the socket release lever straight up until the processor is released from the socket. See [Figure 4-19](#).
9. Lift the processor out of the socket and leave the release lever up so that the socket is ready for the new processor.

NOTICE: Be careful not to bend any of the pins when removing the processor. Bending the pins can permanently damage the processor.

Installing a Processor

CAUTION: See your *System Information Guide* for complete information about safety precautions, working inside the computer, and protecting against electrostatic discharge.

1. Unpack the new processor.

If any of the pins on the processor appear bent, contact the source from whom you purchased the processor.

2. Align the pin-1 corner of the processor with the pin-1 corner of the ZIF socket. See [Figure 4-19](#).

NOTE: Identifying the pin-1 corners is critical to positioning the processor correctly.

Identify the pin-1 corner of the processor by locating the tiny gold triangle on one corner of the processor. Place this corner in the same corner of the ZIF socket identified by a corresponding triangle.

3. Install the processor in the socket.

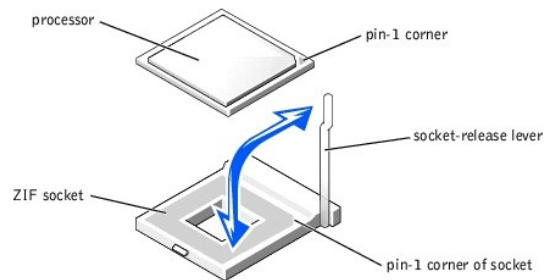

Figure 4-19. Installing the Processor in the Socket

NOTICE: Positioning the processor incorrectly can permanently damage the processor and the system when you turn it on. When placing the processor in the socket, be sure that all of the pins on the processor enter the corresponding holes. Be careful not to bend the pins.

If the release lever on the processor socket is not positioned all the way up, move it to that position.

With the pin-1 corners of the processor and socket aligned, set the processor lightly in the socket, making sure all pins are matched with the correct holes in the socket. Because the system uses a ZIF processor socket, do not use force, which could bend the pins if the processor is misaligned. When the processor is positioned correctly, it drops down into the socket with minimal pressure.

When the processor is fully seated in the socket, rotate the socket release lever back down until it snaps into place, securing the processor.

4. Place the new heat sink on top of the processor, aligning the holes on both sides of the heat sink with the heat-sink posts on the system chassis.
5. Orient the securing clips as shown in [Figure 4-18](#).
6. Position each securing clip over the heat-sink posts, then snap them onto the posts.
7. While holding down the rubber-coated tab with one hand, push the latch on the securing clip on the right until it locks the clip onto the post. While pressing the heat sink down, repeat this step for the securing clip on the left.
8. Replace the cooling shroud.
9. Replace the system cover, and then reconnect the system and peripherals to the power source and turn on the system.

 **NOTE:** When you turn on the system, press the power button for *less than* two seconds. If you press the power button for longer than 3 seconds, the NAS system shuts down.

As the system boots, it detects the presence of the new processor and automatically changes the system configuration information in the System Setup utility.

10. Press <F2> to enter the System Setup utility, and check that the processor information matches the new system configuration.

See "[Using the System Setup Utility](#)" for instructions about using the System Setup utility.

11. Run the System Diagnostics to verify that the new processor operates correctly.

See "[Running the System Diagnostics](#)" for information about running the diagnostics and troubleshooting processor problems.

System Battery

 **CAUTION:** See your *System Information Guide* for complete information about safety precautions, working inside the computer, and protecting against electrostatic discharge.

The system battery maintains your system's configuration, date, and time information in a special section of memory when you turn off the system. The operating life of the battery ranges from 2 to 5 years, depending on how you use the system (for example, if you keep the system turned on most of the time, the battery gets little use, and therefore lasts longer).

You might need to replace the battery if an incorrect time or date displays during the boot routine along with a message about the wrong time, invalid configuration information, or bad CMOS checksum.

To determine if the battery needs replacing:

1. Re-enter the time and date through the System Setup utility. For more information about using the utility, see "[Using the System Setup Utility](#)."

 **NOTICE:** When you turn off the system, press the power button for less than 2 seconds. If you press the power button for longer than 3 seconds, the system will automatically rebuild the RAID arrays the next time the system is turned on. This could impact system performance for several hours.

2. Turn off the system and disconnect it from electrical power for a few hours.
3. After several hours, reconnect the system to a power source and turn it back on.

 **NOTE:** When you turn on the system, press the power button for *less than* two seconds. If you press the power button for longer than 3 seconds, the NAS system shuts down.

4. Enter the System Setup utility.

If the date and time are not correct in the System Setup utility, replace the battery.

 **NOTE:** Some software might cause the system time to speed up or slow down. If the system seems to operate normally except for the time kept in the System Setup utility, the problem may be caused by software rather than by a defective battery.

 **NOTE:** If the system is turned off for long periods of time (for weeks or months), the SDRAM may lose its system configuration information. This loss is *not* caused by a defective battery.

You can operate the system without a battery; however, the system configuration information maintained by the battery in SDRAM is erased each time you shut down the system. Therefore, you must re-enter the system configuration information and reset the options each time the system boots until you replace the battery. The battery is a 3.0-volt (V) battery.

Replacing the Battery

 **CAUTION:** See your *System Information Guide* for complete information about safety precautions, working inside the computer, and protecting against electrostatic discharge.

1. Enter the System Setup utility and, if possible, make a printed copy of the System Setup screens.

See "[Using the System Setup Utility](#)" for instructions on using the utility.

 **NOTICE:** When you turn off the system, press the power button for less than 2 seconds. If you press the power button for longer than 3 seconds, the system will automatically rebuild the RAID arrays the next time the system is turned on. This could impact system performance for several hours.

2. Turn off the system and attached peripherals, and disconnect the system from the electrical outlet.
3. Remove the system cover. See "[Removing the System Cover](#)."
4. Locate the battery on the system board. See [Figure 5-3](#) for the battery location.
5. Grasp the battery with your fingers and pull up to release the battery from the battery socket.
6. Place the new battery with the side labeled "+" facing toward the open side of the battery socket. See [Figure 4-20](#).

Figure 4-20. Replacing the Battery

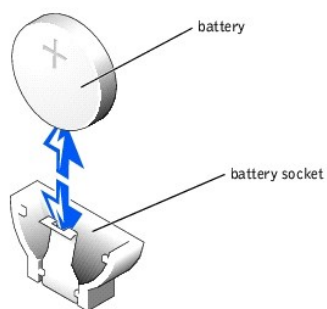

7. Replace the system cover, and then reconnect the system and peripherals to the power source and turn on the system.

 **NOTE:** When you turn on the system, press the power button for *less than* two seconds. If you press the power button for longer than 3 seconds, the NAS system shuts down.

8. Enter the System Setup utility to confirm that the battery operates properly.
9. From the main screen, select **System Time** to enter the correct time and date.

Also, re-enter any system configuration information that is no longer displayed on the System Setup screens, and then exit the System Setup utility.

 **NOTICE:** When you turn off the system, press the power button for less than 2 seconds. If you press the power button for longer than 3 seconds, the system will automatically rebuild the RAID arrays the next time the system is turned on. This could impact system performance for several hours.

10. To test the newly installed battery, turn off the system and disconnect it from electrical power for at least an hour.
11. After an hour, reconnect the system to a power source and turn it on.

12. Enter the System Setup utility. If the time and date are still incorrect, replace the system board. See "[Removing the System Board/Backplane Board Assembly](#)."
-

System Board and Backplane Board

The system board and backplane board provide IDE interface signal routing between the system board and the four IDE hard-drive bays. In addition, the backplane provides power distribution from the power supply to the system board and to internal peripherals.

The system board and backplane board are removed from the chassis as a single assembly, and then are separated for replacement of either board.

Removing the System Board/Backplane Board Assembly

⚠ CAUTION: See your *System Information Guide* for complete information about safety precautions, working inside the computer, and protecting against electrostatic discharge.

To remove the system board/backplane board assembly, perform the following steps:

➡ NOTICE: When you turn off the system, press the power button for less than 2 seconds. If you press the power button for longer than 3 seconds, the system will automatically rebuild the RAID arrays the next time the system is turned on. This could impact system performance for several hours.

1. Turn off the system and attached peripherals, and disconnect the system from the electrical outlet.
2. Remove the system cover. See "[Removing the System Cover](#)."
3. If you are replacing the system board, remove the system battery. See "[Replacing the Battery](#)."
4. If you are replacing the system board, remove the processors. See "[Removing the Processor](#)."
5. If you are replacing the system board, remove the shroud.
6. If you are replacing the system board, remove the memory modules. See "[Removing Memory Modules](#)."
7. Disconnect the control panel cable from the backplane board. See "[Removing the Control Panel](#)."
8. Disconnect all hard drives from the backplane board:
 - a. Push the release lever to the right. See [Figure 4-15](#).
 - b. Open the latch and use it to pull the drive carrier out approximately 2.5 cm (one inch).
 - c. Repeat this step for each installed drive.
9. Rotate the backplane release latches up. See [Figure 4-21](#).
10. Remove the power supply. See "[Removing the Power Supply](#)."
11. Remove the cooling shroud.
12. Remove the blower and fan assemblies. See "[Fan Assemblies](#)."
13. Loosen the thumbscrew securing the system board to the chassis floor.
14. Slide the system board/backplane assembly toward the front of the system and lift the assembly up and out of the chassis. See [Figure 4-21](#).

Figure 4-21. System Board/Backplane Board Assembly Removal

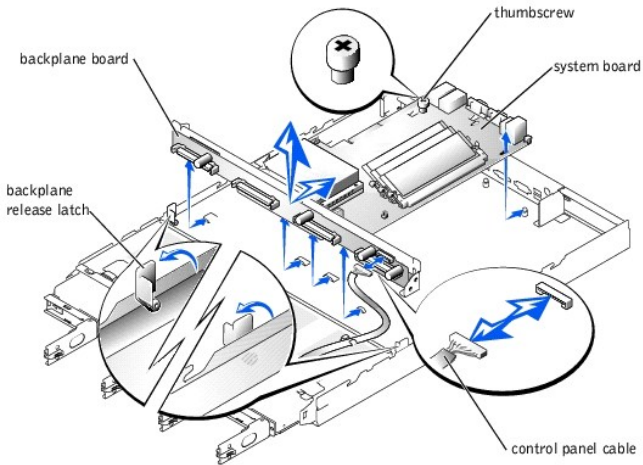

15. Lay the system board/backplane board assembly down on a smooth, nonconductive work surface.
16. Remove the three Phillips screws that secure the system board to the backplane board. See [Figure 4-22](#).

Figure 4-22. Separating or Joining the Backplane and System Boards

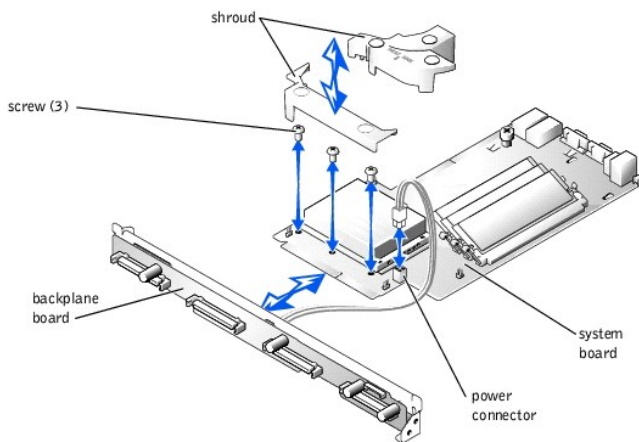

17. Remove the power cable from the power connector on the system board. See [Figure 4-22](#).
18. Remove the other end of the power cable from the back side of the backplane board. See [Figure 5-5](#).
19. Pull the backplane board away from the system board. See [Figure 4-22](#).

Installing the System Board/Backplane Board Assembly

⚠ CAUTION: See your *System Information Guide* for complete information about safety precautions, working inside the computer, and protecting against electrostatic discharge.

To reinstall the replacement system board/backplane board assembly, perform the following steps:

1. Join the two boards together. See [Figure 4-22](#).
2. Secure the two boards with three Phillips screws. See [Figure 4-22](#).
3. Connect the four-conductor power cable from the back of the backplane to the power connector on the system board. See [Figure 4-22](#).
4. Lower the system board/backplane board into the system chassis with the grounding posts through the holes on the system board.
5. Slide the system board/backplane board assembly back towards the system back panel.

Ensure that the tabs on the backplane are threaded through their slots on the system chassis, and that the grounding posts are properly locked in their slotted holes on the system board.

6. Secure the system board to the system chassis by tightening the thumbscrew. See [Figure 4-21](#).
7. Lower the backplane releasing latches to the locked position. See [Figure 4-21](#).
8. Replace the system battery, if it was removed. See "[Replacing the Battery](#)."
9. Replace the processor, if it was removed. See "[Removing the Processor](#)."
10. Replace the cooling shroud, if it was removed.
11. Install the memory modules, if they were removed. See "[Memory](#)."
12. Connect the control panel cable to the front of the backplane. See "[Installing the Control Panel](#)."
13. Install the hard drives into their slots in the drive bay. See "[Installing a Hard Drive](#)."
14. Install the power supply. See "[Installing the Power Supply](#)."
15. Install the riser card. See "[Installing the Riser Card](#)."
16. Install the blower and fan assemblies. See "[Fan Assemblies](#)."
17. Install any expansion card. See "[Installing an Expansion Card](#)."
18. Replace the system cover. See "[Replacing the System Cover](#)."
19. Replace the front panel. See "[Replacing the Front Panel](#)."
20. Reconnect the system to its electrical outlet and turn the system on, including any attached peripherals.

[Back to Contents Page](#)

[Back to Contents Page](#)

Using the System Setup Utility

Dell™ PowerVault™ 725N Systems Service Manual

- [Entering the System Setup Utility](#)
- [System Setup Options](#)
- [Updating the BIOS](#)
- [Changing or Clearing the Supervisor Password](#)
- [Disabling a Forgotten Password](#)

You can use the System Setup utility as follows:

- 1 To change the system configuration after you add, change, or remove hardware
- 1 To set or change user-selectable options—for example, the time or date
- 1 To enable or disable integrated devices

After you set up your system, run the System Setup utility to become familiar with your system configuration information and optional settings. It is recommended that you record the information for future reference.

 **NOTE:** Under normal operating conditions, your Dell™ PowerVault™ NAS system operates as a "headless" system and does not require a keyboard, monitor, and mouse. However, to perform the procedures in this section, you must connect these hardware components to the system.

Entering the System Setup Utility

To enter the System Setup utility, perform the following steps:

1. Connect a keyboard, monitor, and mouse to the system.
2. Turn on or restart your NAS system.

 **NOTE:** When you turn on the system, press the power button for less than two seconds. If you press the power button for longer than 3 seconds, the NAS system shuts down.

3. Press <F2> immediately after you see the following message:

```
Press <F2> to enter the Function Select menu
```

If you wait too long and your operating system begins to load into memory, allow the system to complete the load operation, and then shut down the NAS system and try again.

4. When the Function Select menu appears, press 1 to run the System Setup utility.

Responding to Error Messages

If an error message appears on your screen while the system is booting, make a note of the message. Next, before entering the System Setup utility, see "[Indicators, Messages, and Codes](#)" for an explanation of the message and suggestions for correcting any errors.

Navigating the System Setup Utility

[Table 6-1](#) lists the basic keys used to view or change information in the screens and to exit the program.

Table 6-1. System Setup Navigation Keys

Keys	Action
Down arrow	Moves to the next field.
Up arrow	Moves to the previous field.
Left arrow	Moves to the previous screen.
Right arrow	Moves to the next screen.
<Enter>	Moves to a submenu or selects an item.
<+> <->	Cycles through the settings in a field.
<Esc>	Exits the submenu or the System Setup utility. For most of the options, any changes you make are recorded but do not take effect until the next time you boot the system. For some options (as noted in the Help area), the changes take effect immediately.

System Setup Options

This section provides information about using the System Setup utility to change the default settings on your system.

See the online help for information on submenu items.

Main Screen

[Table 6-2](#) lists the options for the information fields that appear in the **System Setup** screen.

Table 6-2. Main Screen Options

Option	Description
Version	Displays the BIOS version.
BIOS Build Date	Displays the BIOS build date.
Processor Type	Displays the type of processor installed in the system.
Processor Speed	Displays the processor speed.
Processor Cache	Displays the amount of processor cache.
System Memory	Displays the amount of system memory.
System Time	Resets the time on the system's internal clock.
System Date	Resets the date on the system's internal calendar.

Advanced Screen

[Table 6-3](#) lists the options for the information fields that appear in the **Advanced** screen. Use this screen to make changes to the basic operation of your system.

Table 6-3. Advanced Screen Options

Option	Description
IDE Configuration	Displays the characteristics of the IDE2 and IDE3 hard drives, which are the last two drives of the system. The BIOS automatically detects the latest hard drives.
Event Log Configuration	Enables and clears the event logs. See the online help for information on submenu items.
OnBoard Devices Configuration	Enables and disables onboard devices.
System Health Monitoring Hardware	Displays the current system status of the system fans and processor temperature.

Power Screen

[Table 6-4](#) lists the options for the information fields that appear in the **Power** screen. Use this screen to set parameters for system power management operation.

Table 6-4. Power Screen Options

Option	Description
AC Power Failure	Sets the power state after a shutdown caused by an unexpected interruption in AC power. If the value is set to Last State , the system returns to the last power state.
Power Button Mode	Enables or disables the system from booting using the power button.

Boot Screen

[Table 6-5](#) lists the options for the information fields that appear in the **Boot** screen. Use this screen to modify the boot sequences of the internal hard drives.

Table 6-5. Boot Screen Options

Option	Description
Boot Device Priority	Determines where and in which order the system looks for a bootable operating system each time it is started.
Hard Disk Drives	Selects the boot sequence of the hard drives.

Security Screen

[Table 6-6](#) lists the options for the information fields that appear in the **Security** screen. Use this screen to enable the supervisor and user passwords.

Table 6-6. Security Screen Options

Option	Description
Change System Password	Sets a system password.
Clear System Password	Clears a system password.

Exit Screen

[Table 6-7](#) lists the options for the information fields that appear in the **Exit** screen. Use this screen to save or discard any changes to the System Setup utility and default settings.

Table 6-7. Exit Screen Options

Option	Description
Exit Saving Changes	Saves any changes that you made in the System Setup utility and exits.
Exit Discarding Change	Exits the System Setup utility and does not save any changes you made.
Load Optimal Defaults	Configures the settings in the System Setup utility that will provide your system with the best performance.
Discard Changes	Discards any changes you made to the System Setup utility.

Updating the BIOS

See the *System Administrator's Guide* for information about updating the BIOS.

Changing or Clearing the Supervisor Password

Using the System Setup utility, you can change or clear a supervisor password for the BIOS Setup utility. The password is required when the system is booted, or when the user enters the BIOS Setup utility. A supervisor has access to all features in the BIOS Setup utility.

 **NOTE:** The system password is disabled by default. Because the password is required to enter the BIOS Setup utility, do not enable it unless security is a concern.

To change a supervisor password, perform the following steps:

1. Connect a keyboard, monitor, and mouse to the system.
2. Turn on or restart your NAS system.

 **NOTE:** When you turn on the system, press the power button for *less than* 2 seconds. If you press the power button for longer than 3 seconds, the NAS system shuts down.

Press <F2> immediately after you see the following message:

Press <F2> to enter the Function Select menu.

 **NOTICE:** When you turn off the system, press the power button for less than 2 seconds. If you press the power button for longer than 3 seconds, the system will automatically rebuild the RAID arrays the next time the system is turned on. This could impact system performance for several hours.

If you wait too long and your operating system begins to load into memory, allow the system to complete the load operation, and then shut down the NAS system and try again.

3. When the **Function Select** menu appears, press <1> to run the System Setup utility.
4. From the main menu, select **Security**.
5. Select **Change System Password** and press <Enter>.
6. Enter the old password in the dialog box that appears.
7. When prompted, enter the new password (no more than six letters or numbers); or, to clear a password, leave this field blank.
8. Press <Enter>.
9. When prompted, select either **Setup** or **Always**. If you select **Setup**, the password will only be requested when entering the System Setup utility. If you select **Always**, the password will be requested anytime the system is rebooted.
10. To confirm the new password, enter the password again in the dialog box that appears.
11. Press <Enter>.

Disabling a Forgotten Password

 **CAUTION:** See your *System Information Guide* for complete information about safety precautions, working inside the computer, and protecting against electrostatic discharge.

 **NOTICE:** When you turn off the system, press the power button for less than 2 seconds. If you press the power button for longer than 3 seconds, the system will automatically rebuild the RAID arrays the next time the system is turned on. This could impact system performance for several hours.

1. Turn off the system, including any attached peripherals, and disconnect the system from the electrical outlet.
2. Remove the cover. See "[Removing the System Cover](#)."
3. Move the jumper plug from pin 2 to pins 1 and 2.

See Figure 5-2 to locate the password jumper plug (next to the DIMMs and the power supply on the system board).

4. Replace the cover. See "[Replacing the System Cover](#)."

5. Reconnect your system and peripherals to their electrical outlets, and turn on the system.

The password clears.

 **NOTICE:** When you turn off the system, press the power button for less than 2 seconds. If you press the power button for longer than 3 seconds, the system will automatically rebuild the RAID arrays the next time the system is turned on. This could impact system performance for several hours.

6. Turn off the system, including any attached peripherals, and disconnect the system from the electrical outlet.
7. Remove the cover. See "[Removing the System Cover.](#)"
8. Move the jumper plug back to its original position.
9. Replace the cover. See "[Replacing the System Cover.](#)"
10. Reconnect your system and peripherals to their electrical outlets, and turn on the system.

The system has no password protection. See "[Security Screen](#)" for information about setting the password.

[Back to Contents Page](#)